



DELTA BREEZ IAQ SOLUTIONS
Perfectly Quiet. Perfectly Green.





Performance and Exceptional Value

Delta Breez Indoor Air Quality solutions has been honored with the **2022 ENERGY STAR® Partner of the Year for Sustained Excellence** – underscoring our commitment to engineering the most innovative products for a better tomorrow.

Delta Breez is the only manufacturer to exclusively use state-of-the-art brushless DC motors in all of our fans. Here's a sampling of our rich features:

- Save more energy – up to 85% less compared to AC motors
- Exceed ENERGY STAR® efficiency requirements by more than 300%
- Long reliability and trouble-free operation, outlasting AC motors by 2-1/2 times
- Virtually silent - as low as <0.3 sones to maximize homeowner satisfaction
- Optional speed, built-in motion and humidity-sensing controls
- LED lighting, designer grilles and Bluetooth® speakers

CONTENTS

Introduction to Delta	2
DC Motors Explained	3
Importance of Ventilation	4
The Delta Breez Promise	5
Certifications and Qualifications	6
Comprehensive Testing	7
At a Glance: Delta Breez Series Ventilation Fans	8-9
Delta BreezSignature Series	10-15
Delta BreezSmart Series	16-19
Delta BreezElite Series	20-22
Delta BreezRecessed	23
Delta BreezSlim Series	24-29
Delta BreezFresh	30-31
Delta BreezGreenBuilder Series	30-35
Delta BreezIntegrity Series	36-39
Delta BreezRadiance Series	40-41
Delta BreezProfessional Series	42
Delta Breez Fan Curves	43-47
Product Selection Guide	48-51
Equivalent Duct Lengths	52-53
Energy Saving Ventilation Solution	54
Frequently Asked Questions (FAQs)	55-57
Delta Air Mover	58-59
Delta Ceiling Fans	60-63

Smarter. Greener. Together.

VENTILATION RE-IMAGINED

Introduction to Delta

In 2009, Delta Breez ushered in a new era for bathroom ventilation and the Indoor Air Quality (IAQ) industry by launching a line of exhaust fans powered exclusively by DC motors – which are known for their legendary reliability, silent performance and energy-efficiency. By re-inventing the ubiquitous bath fan, we've saved consumers a lot of money on their electricity bills and enabled countless families to breathe easier.

Precision engineering lives in our DNA. In 1971, the Delta Group was founded with the mission of providing “innovative, clean and energy-efficient solutions for a better tomorrow.” We are the world's largest manufacturer of brushless DC fans for all applications from consumer electronics to industrial equipment. Our footprint spans the globe with more than \$9 billion in annual revenues, 39 manufacturing facilities, 70 R&D labs and 169 sales offices. Our U.S. and Americas headquarters is located in the heart of Silicon Valley in Fremont, California.

Innovating for future generations starts today. Our commitment and vision runs deep – with a focus on developing the best and most energy-efficient solutions. In 2018, we sent shockwaves through the industry when we unveiled the market's first edge-lit LED light and bathroom fan combination. Offering consumers new choices is important for us, and Delta will only continue to push the envelope.



FOUNDED

1971

Established by Bruce Cheng in Taipei, Taiwan, to sell various electronic components.



POWER SUPPLIES

1983

Mass production of switching power supplies to become the world's #1 provider.



FANS & MOTORS

1985

Mass production of brushless DC motors and fans to become the world's #1 provider.



DELTA BREEZ IAQ

2009

Global launch of bathroom ventilation fans exclusively powered by DC motors.



LED BATH FANS

2011

Adapting to changing consumer tastes and raising the bar on efficiency, Delta launched the industry's first bathroom exhaust fan and LED light combination.



DC MOTORS EXPLAINED



Reliable. Silent. Efficient. Innovative.

Legendary reliability and performance.

Each DC motor Delta Breez fan is tested to run for 70,000 hours, which is the equivalent of 8 years.

So quiet, you forget it's on.

Brushless technology and precision engineering mean near silent performance, as low as <0.3 sones – the lowest sound rating in the industry.

An energy efficiency workhorse.

Our fans use up to 74% less power than typical AC motor fans, and we exceed ENERGY STAR® requirements for efficiency by as much as 339%

Smart fan technology protects your family.

Our proprietary lock protection system stops the fan from overheating.



**ENERGY STAR®
PARTNER OF
THE YEAR
2016**

Recognizing Delta's exceptional strides in energy efficiency, the U.S. Environmental Protection Agency named Delta ENERGY STAR® Partner of the Year for the first time.



BLUETOOTH 
2017

Feel the rhythm and jam to your favorite tunes! Delta Breez entered the digital era with the first Bluetooth® enabled fans to stream music, sports and news.



**EDGE-LIT
LED LIGHTS
2018**

Delta designed the industry's first ever edge-lit LED bathroom ventilation fans. Disguised as a sleek LED light fixture, our edge-lit LED fans give any bathroom a welcome facelift and is perfect for décor enthusiasts.



**AIR MOVER /
SUPPLY FAN /
CEILING FANS
2022**

Delta introduces the first DC motor centrifugal air mover that is more energy-efficient, quieter, and lighter than ever before.



**ENERGY STAR®
PARTNER-7TH YEAR
2022**

Delta has won Partner of the Year for seven consecutive years and was also honored with the "Sustained Excellence" designation in 2018, 2019, 2020, 2021, and 2022.

IMPORTANCE OF VENTILATION

Ventilation Helps You Breathe Easy

Today's homes are being built tighter than ever and are highly insulated, due to increased standards for energy efficiency in the building code. However, this can result in poor indoor air quality with unhealthy air being sealed behind windows and doors. Without adequate air exhaust, the concentration of indoor pollutants exponentially increases. Delta Breez bathroom ventilation fans help you breathe easy by exhausting the air when you need it. Our DC motor powered fans are built upon the quality and engineering expertise of nearly half a century of innovation. Ventilation is essential to improve indoor air quality. A reliable ventilation system must have the proper air flow for the designated space and be operated regularly.



Indoor Air Pollution

Indoor air pollutants are found throughout the home including combustion sources, building materials and cleaning products. Biological pollutants include mold, mildew, bacteria and pollen. Together, these pollutants can cause and exacerbate health problems, especially respiratory illnesses. High humidity and uncontrolled moisture in the home can result in higher pollutant concentrations, and increased growth of biological contaminants.



THE DELTA BREEZ PROMISE

The Path to Fresh Air

Delta Breez fans control and reduce the moisture in your home to improve indoor air quality, and minimizing the risk of health problems. High humidity conditions typically result from showering and bathing. Therefore, proper bathroom ventilation is essential to improve indoor air quality. A reliable ventilation system must have the proper air flow for the designated space and be operated regularly.



A Visionary in IAQ

Delta Breez leads the Indoor Air Quality (IAQ) industry with bathroom ventilation fans that are the gold standard for energy efficiency – saving consumers energy and money on their utility bills. All Delta Breez fans are powered by our signature brushless DC motor technology, which stands for unparalleled efficiency, legendary reliability and virtually silent operation.



CERTIFICATIONS AND QUALIFICATIONS



ENERGY STAR

ENERGY STAR, a joint program of the U.S. Department of Energy and the U.S. Environmental Protection Agency, identifies products in over 60 categories which meet rigorous energy efficiency standards. Established in 1992, ENERGY STAR is an internationally recognized label for U.S.-originating products that reduce greenhouse gas emissions without sacrificing performance or quality. ENERGY STAR-qualified products protect the environment by reducing energy consumption, which also reduces greenhouse gas emissions and saves consumers money on utility bills.

As an ENERGY STAR partner, Delta strives to engineer solutions that meet and surpass current standards in energy efficiency. Delta Breez prides ourselves on delivering ENERGY STAR-qualified products, some of which exceed the ENERGY STAR efficiency requirement by over 315%. With 104 ventilation fan models evaluated in 2021, 95 (91%) models were recognized as ENERGY STAR-qualified.

For more information, visit
www.energystar.gov

ENERGY STAR Most Efficient 2022



**Most Efficient
2022**
www.energystar.gov

ENERGY STAR Most Efficient is a designation that recognizes the top products for the ENERGY STAR label.

Delta Breez currently has 95 ENERGY STAR®-qualified bathroom fans, with some models even exceeding the criteria by 315 percent. In fact, 30 fans from the Delta BreezSignature and BreezElite lines meet the toughest efficiency criteria set by the EPA – ENERGY STAR® Most Efficient 2022.



CALGreen is a state building code requirement for California that sets baseline efficiency and sustainability standards. High efficiency products such as Delta Breez ventilation fans help builders meet this requirement.

For more information, visit

www.bsc.ca.gov/Home/CALGreen.aspx



HVI, the Home Ventilating Institute, is an organization that runs a standardized testing and certification program for a range of home ventilating products. Products are tested to qualify for various performance parameters and undergo random verification. All tests are conducted in third-party facilities that are independent of any manufacturer, while testing procedures are designed by HVI members according to internationally recognized guidelines. All Delta Breez ventilation fans are HVI lab tested and certified.

For more information about HVI, please visit: www.hvi.org



ASHRAE 62.2

ASHRAE 62.2 publishes a national standard that applies to single-family homes and multi-family dwellings to ensure proper ventilation and acceptable indoor air quality. The standard is referenced in building codes and widely accepted by architects, engineers and mechanical contractors. ASHRAE 62.2 addresses minimum ventilation effectiveness and noise level performance of continuous and intermittent mechanical exhaust systems.

The following table summarizes the ventilation air requirements in CFM for various floor areas:

Ventilation Air Requirement, CFM

Floor Area (ft ²)	Bedrooms				
	0-1	2-3	4-5	6-7	>7
<1500	30	45	60	75	90
1501-3000	45	60	75	90	105
3001-4500	60	75	90	105	120
4501-5000	75	90	105	120	135
5001-7500	90	105	120	135	150
>7500	105	120	135	150	165

Most Delta Breez fan models are ASHRAE 62.2 compliant for both intermittent and continuous run applications. This means Delta Breez fans are operable according to 62.2 guidelines for airflow and meet the minimum noise level requirements.

COMPREHENSIVE TESTING ENSURES RELIABILITY

Testing procedures for ventilation fan reliability verification are conducted before, during and after production. Customers can rest easy, knowing the product's durability and long lifespan.

Design and Analysis Technology

Delta's design and analysis technology utilizes 3D and 2D tools to conduct thorough examinations during the design and production phases. Software simulations help enable the highest standards of performance.

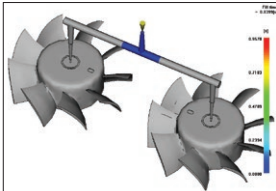
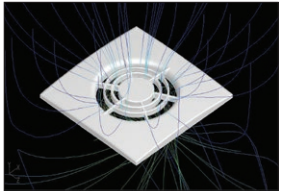
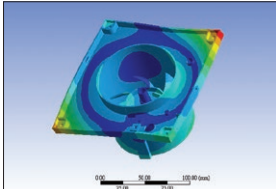
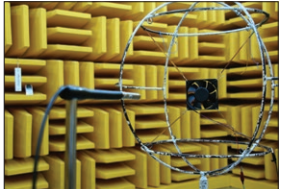
<p>Moldflow Analysis Software Plastic mold</p>		<p>Aerodynamic Simulation Software Fan blade curve design and air flow analysis</p>	
<p>Structure Simulation Software Structural analysis for stress and vibration</p>		<p>Semi-Anechoic Chamber Noise testing for sound pressure and sound quality</p>	

Physical Testing for Ventilation Fan Reliability

Laboratory testing of Delta Breez products analyzes functionality and durability under harsh conditions, as well as construction for long life. The Basic Function Test checks current, speed and noise. The Safety Test includes leakage current, Hipot (high potential), ground bond and insulation testing. Comprehensive reliability testing continues with:

- Low Temperature and High Temp/Rating Voltage on/off Test
- Temperature Cycling and Power Switching
- Impeller Locked Test
- Thermal Shock
- Humidity Exposure
- Water Spray
- Random Vibration and Drop (packing)
- Operational and Non-operational Vibration
- Mechanical Shock
- Life Test

Brushless DC Motor Fan Highlights

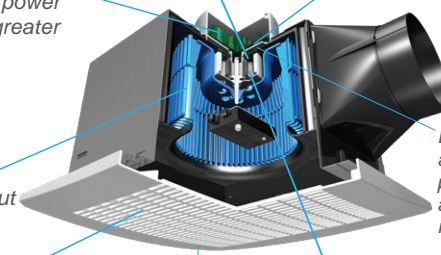
Cycling switch to control on dual speed and humidity sensing models

A switch power supply and the unit's brushless DC motor reduce power consumption for greater energy efficiency

Soft-start control reduces current impulse and start-up noise

Impeller includes 67 fins to help reduce noise output

Lock protection automatically powers off and on after 10 seconds if lock releases

Humidity control option-rotation speed can vary on humidity sensing models output

A highly efficient brushless DC motor features a ball bearings design to enhance the life of the product

Light-weight design for easy installation



Delta Breez Series Ventilation Fans

DeltaBreez is the only residential bathroom exhaust fan manufacturer that can deliver a powerful combination of ENERGY STAR®-qualification, performance, quietness, state-of-the-art brushless DC motor technology and affordability in every fan. Optional built-in speed, motion and/or humidity-sensing controls — plus decorative or edge-lit dimmable LED lighting, heater, designer fan grille and Bluetooth® speakers, to satisfy consumer preferences and building codes.

Choose from nine different series:



Virtually silent, feature-rich. One of our highest performing, most quiet series at less than 0.3 sones. High speed 80 or 110 CFM. For spaces 80-110 sq. ft. Options include adjustable high and/or low speeds, dimmable LED light or dimmable edge-lit LED light, motion and/or adjustable humidity sensor, Bluetooth® speaker. Ceiling Radiation Damper, designer grille, and metal grille available separately. UL listed for ceiling mount only.



Virtually silent, feature-rich. One of our highest performing, most quiet series at less than 0.3 sones. High speed 130 CFM, 150 CFM, or 200 CFM. For spaces 130 to 200 sq. ft. Options include adjustable low speeds, LED light, motion or adjustable humidity sensor. Ceiling Radiation Damper and metal grille available separately. UL listed for ceiling mount only.



Affordable performance, feature-rich with very quiet operation from 0.5 to 0.7 sones. Innovative, pocket mounting brackets stay hidden and slide out for room-side installation in remodeling projects and for time-saving installation in new construction projects, a solution where space is at a premium. High speed 80 or 110 CFM. For spaces 80-110 sq. ft. Options include adjustable high and/or low speeds, dimmable LED light, motion and/or adjustable humidity sensor. Ceiling Radiation Damper available. UL listed for ceiling mount only.



Builders' best solution. High speed 80 or 100 CFM. For spaces 80-100 sq. ft. Quiet operation from 0.8 to 1.5 sones. Options include adjustable low speed, dimmable LED light, and decorative LED light, motion and/or humidity sensor. Ceiling Radiation Damper and designer grille available separately. Fan only and fans with humidity sensor are UL listed for ceiling and wall mount; fans/LED light are UL listed for ceiling mount only.



Economical solution. Single speed 50, 80 or 100 CFM. For spaces 50-100 sq. ft. Quiet operation from 0.7 to 1.5 sones. Options include dimmable LED light or dimmable edge-lit LED light, adjustable humidity sensor, Bluetooth® speaker. Ceiling Radiation Damper and designer grille available separately. Fan only and fans with humidity sensor are UL listed for ceiling and wall mount; fans/LED light are UL listed for ceiling mount only.



breez Slim

Ultimate multi-family solution. Single speed 50, 70, 80, 100, dual speed 70, and high speed 80 or 110 CFM. For spaces 50-110 sq. ft. Quiet operation from 0.4 to 2.0 sones. Options include adjustable high and/or low speeds, dimmable LED light, dual speed or built-in humidity sensor. Low profile, with 4" deep housing to fit in 2x4 sidewalls. Designer grille available separately for SLM50, SLM70, SLM70D and SLM70H. Ceiling Radiation Damper available separately for SLM80, SLM100. UL listed for ceiling and wall mount.

breez Recessed

Fan design solution. 80 CFM fan disguised as a recessed light with LED main and night light. For 80 sq. ft. spaces. Quiet operation at 1.5 sones. UL approved for ceiling mount only.

breez Radiance

Fan/heater solution to warm and delight. Quiet operation from 0.7 to 1.5 sones. 80 or 110 CFM for spaces 80-110 sq. ft. Options include dimmable LED light, or fan/heater only. Built-in thermostat to regulate room temperature for maximum comfort. UL approved for ceiling mount only.

breez Pro

Large space solution. Single speed 300 CFM. Quiet operation from 1.0 to 2.0 sones. For spaces 300 sq. ft. Perfect for large bathrooms, laundry rooms, and conference rooms. UL approved for ceiling mount only.





6 Inch Duct Series

Virtually silent, feature-rich. Our highest performing, most quiet series at less than 0.3 sones.

High speed 80 or 110 CFM. For spaces 80-110 sq. ft. Options include adjustable high and/or low speeds, dimmable LED light and edge-lit LED light, motion and/or adjustable humidity sensor. Ceiling Radiation Damper, designer grille, and metal grille available separately. UL listed for ceiling mount only.

Features:

- Energy savings up to 127%¹ and 6" metal duct
- <0.3 sones - lowest noise level among competing fans
- Exceed Energy Star efficiency standards by 450%²
- Adjustable high speed of 80 or 110 CFM
- Dual speed, motion-sensing and humidity-sensing options with continuous adjustable low-speed
- Includes 6" to 4" duct reducer

Fan/Dimmable LED Light:

- 13-Watt LED main light and 2-Watt LED night light
- Main light output of 850 lumens, 3000K and 90 CRI
- Dimmable LED light (dimmer switch not included)

Fan/Edge-Lit Dimmable LED Light with Adjustable Color Temperature 3000K, 4000K and 5000K

- 13-Watt LED main light output 1000 lumens

1. Based upon SIG80-110 vs. market AC motor.

2. Based upon SIG 80 CFM vs. ENERGY STAR v4.0 criteria for residential ventilating fans



Fan only and Fans with Humidity Sensor or Dual Speed



Fan/Edge-lit Dimmable LED Light

- 3000K
 - 4000K
 - 5000K
- CCT switch



Fan/ Dimmable LED Light/ Night-Light (Options: Fan with Dual Speed, Humidity Sensor or Motion Sensor)



High Speed Switch



Adapter 4 inches

BreezSignature Series Dimensions

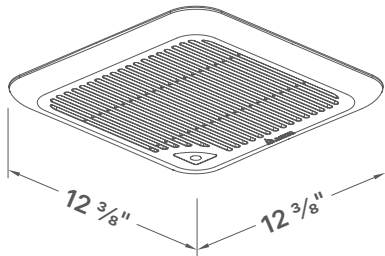
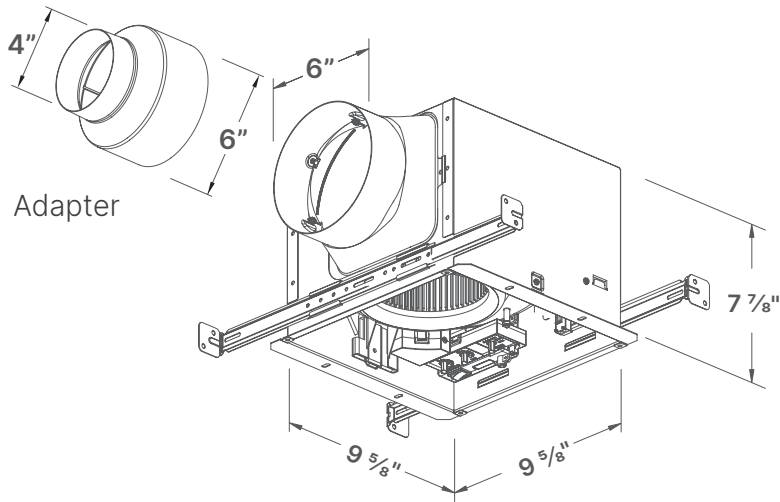

Fan Grille w/ motion sensor

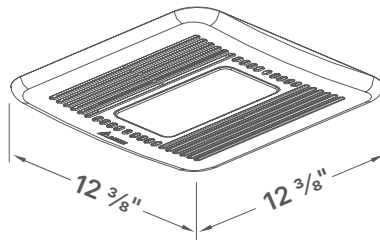

Fan/Dimmable LED Light Grille

SIG80-110H
SIG80-110HLED
SIG80-110MH
SIG80-110MHLED
Controls

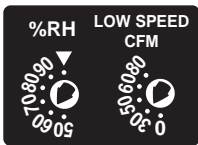

SIG80-110D
SIG80-110DLED
Controls

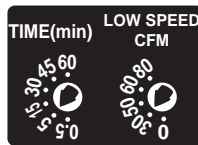

SIG80-110MHLED
Motion
Controls



LED Indicator Light:
SIG80-110,
SIG80-110LED



LED Indicator Light: SIG80-110D
Continuous
Low Speed Full Speed



LED Indicator Light: SIG80-110H,
SIG80-110HLED, SIG80-110MH

Humidity Sensing



Full Speed



LED Indicator Light: SIG80-110DLED

Low Speed

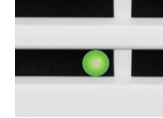

Full Speed



LED Indicator Light: SIG80-110MHLED

Low Speed



Full Speed



	Delta Breez	Market AC Motor
Energy Use (Watts)	6.2	31.4
Noise Level (Sones)	<0.3	0.7
Annual Energy Cost per Fan (24/7) ¹	\$6.50	\$33.03

1. Calculations based upon U.S. average retail electricity. Actual results may vary

Specifications

SIG80-110 - 80/110 CFM Fan



	0.1	0.25	0.1	0.25
Static Pressure (Inches w.g.)	0.1	0.25	0.1	0.25
Air Flow (CFM)	80	80	110	110
Sones	<0.3	0.5	<0.3	0.8
Power Consumption (Watts)	6.2	9.9	8.2	14.1
Energy Efficiency (CFM/Watts)	15.4	9.0	15.3	8.7
Current (Amps)	0.38 Max			
Power Rating (V/Hz)	120/60			



6 Inch Duct Series Specifications

SIG80-110ELED - 80/110 CFM Fan/ **Edge-lit Dimmable LED Light w/ adjustable color temperature**

Fan Speed	Continuous Low Speed								Full Speed			
Static Pressure (Inches w.g.)	0.1	0.25	0.1	0.25	0.1	0.25	0.1	0.25	0.1	0.25	0.1	0.25
Air Flow (CFM)	80	80	110	110	80	80	110	110	80	80	110	110
Sones	<0.3	0.8	0.5	1.0	<0.3	0.8	0.5	1.0	<0.3	0.5	<0.3	0.8
Power Consumption (Watts)	7.5	11.5	9.9	15.5	7.5	11.5	9.9	15.5	7.5	11.5	9.9	15.5
Energy Efficiency (CFM/Watts)	11.7	7.6	11.8	7.3	11.7	7.6	11.8	7.3	11.7	7.6	11.8	7.3
Current (Amps)	0.48 Max											
Power Rating (V/Hz)	120/60											
LED Light (Watts/Lumens)	13/1000											

SIG80-110LED - 80/110 CFM Fan/ **Dimmable LED Light/Night-Light**

Fan Speed	Continuous Low Speed								Full Speed			
Static Pressure (Inches w.g.)	0.1	0.25	0.1	0.25	0.1	0.25	0.1	0.25	0.1	0.25	0.1	0.25
Air Flow (CFM)	80	80	110	110	80	80	110	110	80	80	110	110
Sones	<0.3	0.5	<0.3	0.8	<0.3	0.5	<0.3	0.8	<0.3	0.5	<0.3	0.8
Power Consumption (Watts)	6.8	9.9	9.7	15.5	6.8	9.9	9.7	15.5	6.8	9.9	9.7	15.5
Energy Efficiency (CFM/Watts)	13.8	8.4	12.7	8.0	13.8	8.4	12.7	8.0	13.8	8.4	12.7	8.0
Current (Amps)	0.48 Max											
Power Rating (V/Hz)	120/60											
Light (Watts/Lumens)	13/800											
Night Light (Watts)	2											

SIG80-110D - 80/110 CFM **Fan with Dual Speed**

Fan Speed	Continuous Low Speed								Full Speed			
Static Pressure (in w.g.)	0.1	0.25	0.1	0.25	0.1	0.25	0.1	0.25	0.1	0.25	0.1	0.25
Air Flow (CFM)	30	30	50	50	60	60	80	80	80	80	110	110
Sones	<0.3	<0.3	<0.3	<0.3	<0.3	0.3	<0.3	0.5	<0.3	0.5	<0.3	0.8
Power (Watts)	4.4	6.3	4.8	7.3	5.5	8.6	6.2	9.9	6.2	9.9	8.2	14.1
Efficiency (CFM/Watts)	9.0	5.9	13.5	8.0	13.3	8.0	15.4	9.0	15.4	9.0	15.3	8.7
Current (Amps)	0.38 Max											
Power Rating (V/Hz)	120/60											

SIG80-110DLED - 80/110 CFM **Fan/Dimmable LED Light/Night-Light with Dual Speed**

Fan Speed	Continuous Low Speed								Full Speed			
Static Pressure (in w.g.)	0.1	0.25	0.1	0.25	0.1	0.25	0.1	0.25	0.1	0.25	0.1	0.25
Air Flow (CFM)	30	30	50	50	60	60	80	80	80	80	110	110
Sones	<0.3	<0.3	<0.3	<0.3	<0.3	0.3	<0.3	0.5	<0.3	0.5	<0.3	0.8
Power (Watts)	4.4	6.7	5.2	8.2	5.6	8.7	6.8	9.9	6.8	9.9	9.7	15.5
Efficiency (CFM/Watts)	9.5	5.8	12.3	7.1	13.2	8.0	13.8	8.4	13.8	8.4	12.7	8.0
Current (Amps)	0.48 Max											
Power Rating (V/Hz)	120/60											
Light (Watts/Lumens)	13/1000											
Night Light (Watts)	2											

SIG80-110H - 80/110 CFM **Fan with Humidity Sensor**

Fan Speed	Continuous Low Speed								Full Speed			
Static Pressure (in w.g.)	0.1	0.25	0.1	0.25	0.1	0.25	0.1	0.25	0.1	0.25	0.1	0.25
Air Flow (CFM)	30	30	50	50	60	60	80	80	80	80	110	110
Sones	<0.3	<0.3	<0.3	<0.3	<0.3	0.3	<0.3	0.5	<0.3	0.5	<0.3	0.8
Power (Watts)	4.4	6.3	4.8	7.3	5.5	8.6	6.2	9.9	6.2	9.9	8.2	14.1
Efficiency (CFM/Watts)	9.0	5.9	13.5	8.0	13.3	8.0	15.4	9.0	15.4	9.0	15.3	8.7
Current (Amps)	0.38 Max											
Power Rating (V/Hz)	120/60											

SIG80-110HLED - 80/110 CFM **Fan/Dimmable LED Light/Night-Light with Humidity Sensor**

Fan Speed	Continuous Low Speed								Full Speed			
Static Pressure (in w.g.)	0.1	0.25	0.1	0.25	0.1	0.25	0.1	0.25	0.1	0.25	0.1	0.25
Air Flow (CFM)	30	30	50	50	60	60	80	80	80	80	110	110
Sones	<0.3	<0.3	<0.3	<0.3	<0.3	0.3	<0.3	0.5	<0.3	0.5	<0.3	0.8
Power (Watts)	4.4	6.7	5.2	8.2	5.6	8.7	6.8	9.9	6.8	9.9	9.7	15.5
Efficiency (CFM/Watts)	9.5	5.8	12.3	7.1	13.2	8.0	13.8	8.4	13.8	8.4	12.7	8.0
Current (Amps)	0.48 Max											
Power Rating (V/Hz)	120/60											
Light (Watts/Lumens)	13/800											
Night Light (Watts)	2											

SIG80-110MH - 80/110 CFM **Fan with Motion and Humidity Sensor**

Fan Speed	Continuous Low Speed								Full Speed			
Static Pressure (in w.g.)	0.1	0.25	0.1	0.25	0.1	0.25	0.1	0.25	0.1	0.25	0.1	0.25
Air Flow (CFM)	30	30	50	50	60	60	80	80	80	80	110	110
Sones	<0.3	<0.3	<0.3	<0.3	<0.3	0.3	<0.3	0.5	<0.3	0.5	<0.3	0.8
Power (Watts)	4.4	6.3	4.8	7.3	5.5	8.6	6.2	9.9	6.2	9.9	8.2	14.1
Efficiency (CFM/Watts)	9.0	5.9	13.5	8.0	13.3	8.0	15.4	9.0	15.4	9.0	15.3	8.7
Current (Amps)	0.38 Max											
Power Rating (V/Hz)	120/60											

SIG80-110MHLED - 80/110 CFM **Fan/Dimmable LED Light/Night-Light w/ Motion and Humidity Sensor**

Fan Speed	Continuous Low Speed								Full Speed			
Static Pressure (in w.g.)	0.1	0.25	0.1	0.25	0.1	0.25	0.1	0.25	0.1	0.25	0.1	0.25
Air Flow (CFM)	30	30	50	50	60	60	80	80	80	80	110	110
Sones	<0.3	<0.3	<0.3	<0.3	<0.3	0.3	<0.3	0.5	<0.3	0.5	<0.3	0.8
Power (Watts)	4.4	6.7	5.2	8.2	5.6	8.7	6.8	9.9	6.8	9.9	9.7	15.5
Efficiency (CFM/Watts)	9.5	5.8	12.3	7.1	13.2	8.0	13.8	8.4	13.8	8.4	12.7	8.0
Current (Amps)	0.48 Max											
Power Rating (V/Hz)	120/60											
Light (Watts/Lumens)	13/800											
Night Light (Watts)	2											

4 Inch Duct Series

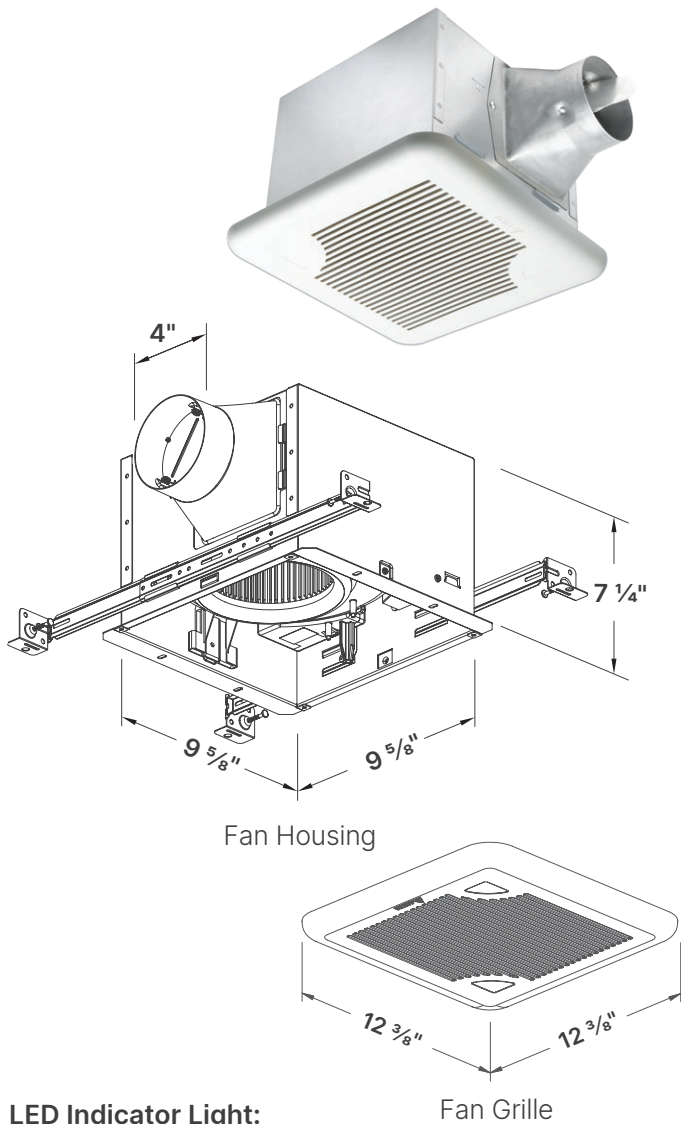

LED Indicator Light:
SIG80 and SIG110

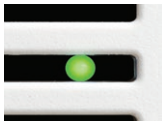

LED Indicator Light: SIG80D

Continuous
Low Speed

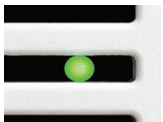

Full Speed



SIG80D
Controls

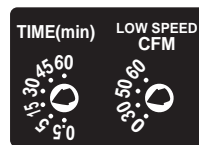

Specifications

SIG80 - 80 CFM Single Speed Exhaust Fan



Static Pressure (in w.g.)	0.1	0.25
Air Flow (CFM)	80	79
Sones	<0.3	0.5
Power Consumption (Watts)	8.7	14.0
Energy Efficiency (CFM/Watts)	9.7	6.3
Current (Amps)	0.30 Max	
Power Rating (V/Hz)	120/60	

SIG80D - 80 CFM Dual Speed Exhaust Fan



Static Pressure (in w.g.)	0.1	0.25	0.1	0.25	0.1	0.25	0.1	0.25
Air Flow (CFM)	30	31	50	50	60	61	80	79
Sones	<0.3	<0.3	<0.3	<0.3	<0.3	0.3	<0.3	0.5
Power (Watts)	4.8	8.9	6.6	9.8	6.7	11.8	8.7	14.0
Efficiency (CFM/Watts)	7.7	4.1	8.4	5.2	9.9	5.6	9.7	6.3
Current (Amps)	0.30 Max							
Power Rating (V/Hz)	120/60							

SIG110 - 110 CFM Single Speed Exhaust Fan



Static Pressure (in w.g.)	0.1	0.25
Air Flow (CFM)	110	95
Sones	<0.3	0.6
Power Consumption (Watts)	13.6	16.0
Efficiency (CFM/Watts)	9.0	6.4
Current (Amps)	0.38 Max	
Power Rating (V/Hz)	120/60	

	Delta Breez	Market AC Motor
Energy Use (Watts)	8.7	28.4
Noise Level (Sones)	<0.3	0.8
Annual Energy Cost per Fan (24/7) ¹	\$9.15	\$29.94

1. Calculations based upon U.S. average retail electricity. Actual results may vary



4 Inch Duct Series

VFB25ADBT 110 CFM Fan with Bluetooth® stereo speaker enables you to enjoy your favorite music, or listen to news, weather, traffic or sports while the energy-efficient fan quietly ventilates your bathroom. Easily pairs with most Bluetooth wireless devices. Quiet operation at 1.0 sone, so you hear your entertainment, not the fan.

Features:

Long-lasting, brushless DC motor engineered to operate minimum 70,000 hours.

- Includes a built-in Bluetooth 2.1, Stereo Speaker 4 ohm 2W x 2
- Pair with most Bluetooth wireless devices
- Attractive grille complements any décor

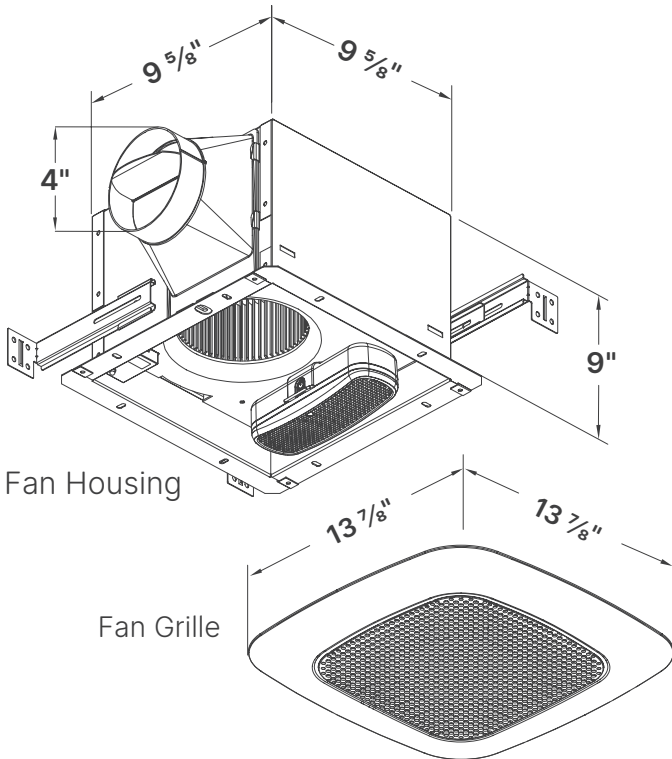

Fan with Bluetooth® Speaker

Specifications

VFB25ADBT - 110 CFM Fan with Bluetooth



	0.1	0.25
Static Pressure (Inches w.g.)	0.1	0.25
Air Flow (CFM)	110	81
Sones	1.0	1.5
Power Consumption (Watts)	14.2	15.0
Energy Efficiency (CFM/Watts)	7.7	5.3
Current (Amps)	0.3 @ 110 Vac	
Power Rating (V/Hz)	110~220/50~60	

The Bluetooth® word mark and logos are registered trademarks owned by Bluetooth® SIG, Inc. and any use of such marks by Delta Electronics, Inc. is under license. Other trademarks and trade names are those of their respective owners.

	Delta Breez	Market AC Motor
Energy Use (Watts)	14.2	34
Noise Level (Sones)	1.0	1.5
Annual Energy Cost per Fan (24/7) ²	\$14.94	\$35.91

1. Based upon ENERGY STAR criteria for residential ventilating fans.
2. Based upon BreezSignature VFB25ACH vs. market AC motor fan.

Ceiling Radiation Damper SIG-CRD

The damper employs a folded curtain style blade for point-of-origin control of radiant heat in a ventilation system. SIG-CRD installs in the ceiling membrane for floor/ceiling or roof/ceiling assemblies with a fire resistance rating up to and including 3 hours.

Features:

- UL listed as fan/damper assembly for the following Wood Frame Construction designs: L521, L546, L558, L562, L574, L576, L581, L583, L585, P522, P533, P538 and P545
- Meets both UL555C and UL263. UL and cUL listed and exceeds UL 555C for use in 3-hour fire rated assemblies
- Warnock-Hersey certified for use in fire rated floor ceiling or roof/ceiling assemblies. Warnock Hersey listing #: 102195501SAT-002
- CSFM listing: 3226-0368:104
- UL 555C listing: R27832
- Meets NFPA Standards: 90A and 101
- Meets Building Code Standards: IBC, NBC, NFPA, SBC, & UBC
- Available for use with Delta Breez SIG Series ventilation fans

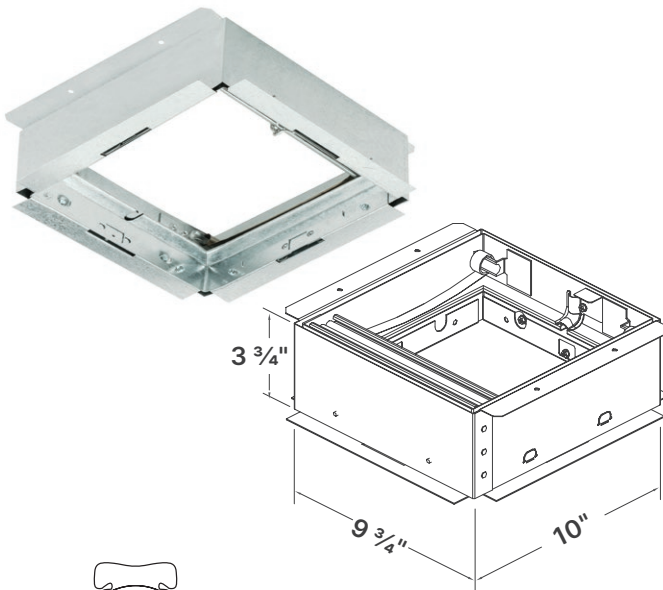

Metal Grille SIG-MTL

The SIG-MTL metal grille is offered as an alternative to the standard grille on Delta Breez SIG80, SIG80D, SIG110, SIG80-110, SIG80-110D, SIG80-110H.

Features:

- Adds modern aesthetic to bathroom
- Made of galvanized steel material and painted white
- Paintable for added customization
- Size: 13 × 13 × 3/8 inches

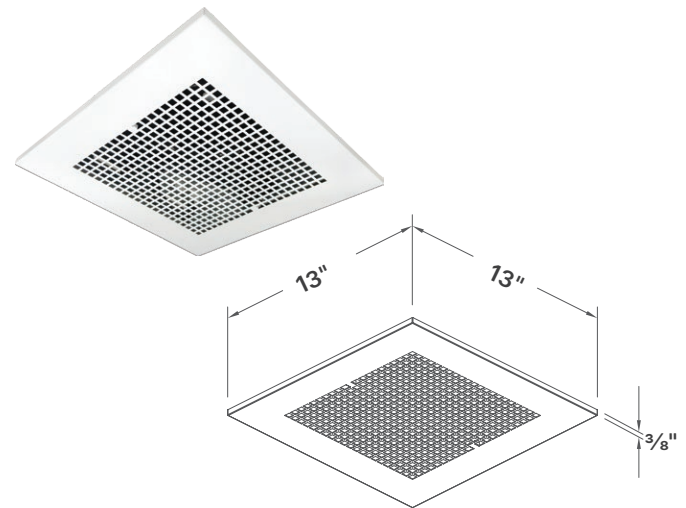

Designer Grille SIG-DGL

The SIG-DGL designer fan grille is offered as an alternative to the standard grille on Delta Breez SIG80, SIG80D, SIG110, SIG80-110, SIG80-110D, SIG80-110H

Features:

- Adds modern aesthetic to bathroom
- Made of long lasting ABS material
- Paintable to coordinate with any style bathroom
- Size: 12 3/8" x 12 3/8"

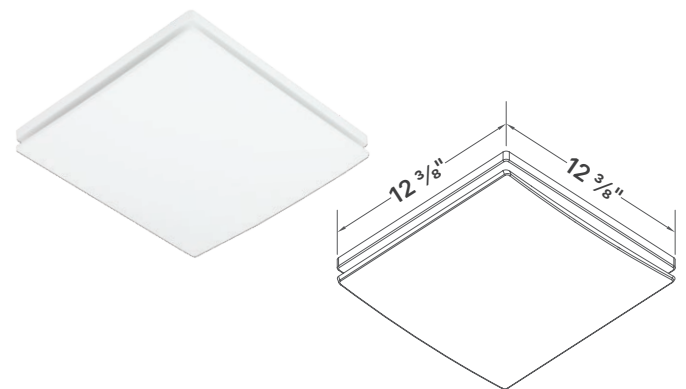



6 Inch Duct Series

The Smart Choice. Virtually silent, feature-rich.

Delta BreezSmart Series is the perfect ventilation solution for today's larger, spa-style bathrooms. One of our highest performing, most quiet at less than 0.3 sones. High speed 130 or 150 CFM, or adjustable high speed 150-200 CFM. For spaces 130-200 sq. ft. Options include adjustable low speeds, LED light, motion or adjustable humidity sensor. Ceiling Radiation Damper and metal grille available separately. UL listed for ceiling mount only.

Features:

- Energy savings up to 57.9%¹
- <0.3 sones - lowest noise level among competing fans
- Exceeds ENERGY STAR requirement by 151% in energy efficiency²
- Motion-sensing, humidity-sensing, LED and dual-speed options available with user-adjustable continuous low speed

Fan/Dimmable LED light:

- 13-Watt LED main light and 2-Watt LED night light
- Main light output of 850 Lumens, 3000K and 90 CRI Dimmable LED Light (dimmer switch not included)

Fan/Dimmable LED light with Adjustable Color Temperature 3000K, 4000K and 5000K:

- 13-Watt LED light output of 850 Lumens and 90 CRI

1. Based upon BreezSmart SMT150-200 (200 CFM) vs. market AC motor fan
 2. Based upon SMT 150 CFM vs. ENERGY STAR v4.0 criteria for residential fans

	Delta Breez	Market AC Motor
Energy Use (Watts)	24	57
Noise Level (Sones)	1.0	1.2
Annual Energy Cost per Fan (24/7) ³	\$24.67	\$58.59

3. Calculations based upon U.S. average retail electricity. Actual results may vary

Fans with adjustable high speed options (150-200 CFM)



High Speed Switch

Fan/Dimmable LED Light

- 3000K
- 4000K
- 5000K



High Speed Fans (130 CFM or 150 CFM)



LED Indicator Light: SMT130, SMT150, SMT150LED, SMT150-200, & SMT150-200LED

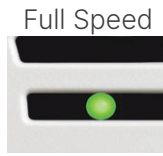

LED Indicator Light: SMT130M, SMT150D
Continuous Low Speed Full Speed



LED Indicator Light: SMT130H
Humidity Sensing Full Speed



Built-in Controls

SMT130H Controls

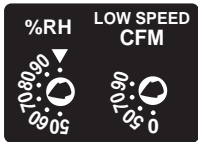

SMT130M Controls

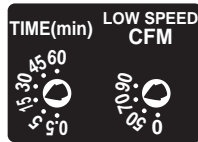

SMT150D Controls

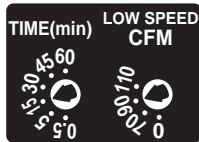

BreezSmart Series Dimensions

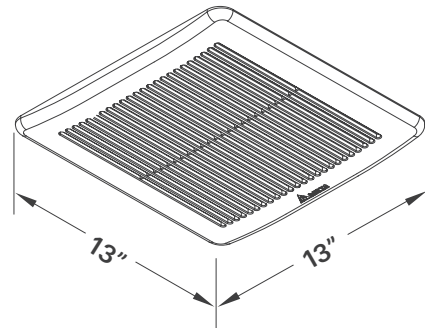

Fan Grille

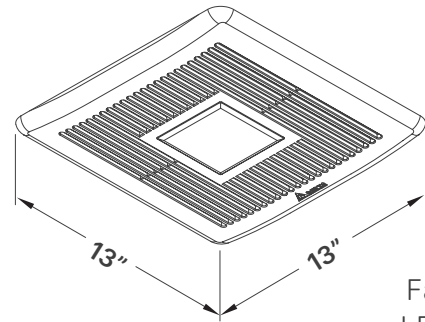

Fan/Dimmable LED Light Grille

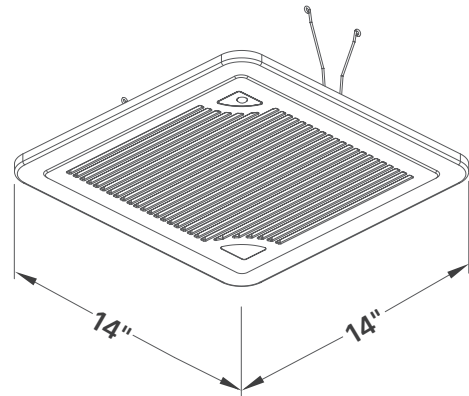

Fan Grille

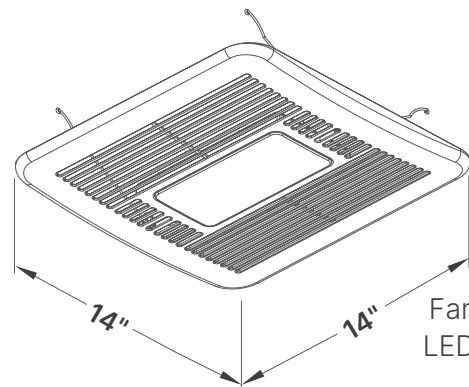

Fan/Dimmable LED Light Grille

BreezSmart Series Dimensions

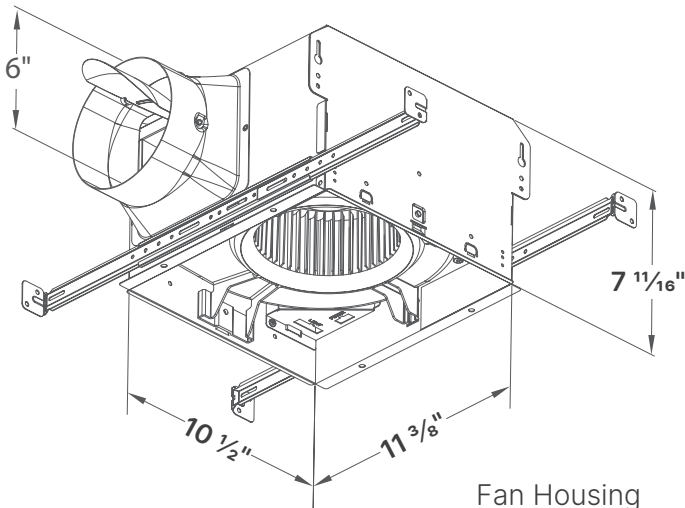

Fan Housing



Specifications

SMT130* - 130 CFM Single Speed Exhaust Fan



Fan Speed	Continuous Low Speed	Full Speed
Static Pressure (Inches w.g.)	0.1	0.25
Air Flow (CFM)	130	124
Sones	<0.3	1.0
Power Consumption (Watts)	11.6	20.0
Energy Efficiency (CFM/Watts)	11.2	6.2
Current (Amps)	0.44 Max	
Power Rating (V/Hz)	120/60	

SMT130H* - 130 CFM with Humidity Sensor



Fan Speed	Continuous Low Speed						Full Speed	
Static Pressure (Inches w.g.)	0.1	0.25	0.1	0.25	0.1	0.25	0.1	0.25
Air Flow (CFM)	50	49	70	68	90	88	130	124
Sones	<0.3	1.0	<0.3	1.0	<0.3	1.0	<0.3	1.0
Power Consumption (Watts)	5.6	12.2	6.9	13.5	8.0	15.5	11.6	20.0
Energy Efficiency (CFM/Watts)	8.9	4.0	10.1	5.0	11.2	5.6	11.2	6.2
Current (Amps)	0.44 Max							
Power Rating (V/Hz)	120/60							

SMT130M* - 130 CFM with Motion Sensor



Fan Speed	Continuous Low Speed						Full Speed	
Static Pressure (Inches w.g.)	0.1	0.25	0.1	0.25	0.1	0.25	0.1	0.25
Air Flow (CFM)	50	49	70	68	90	88	130	124
Sones	<0.3	1.0	<0.3	1.0	<0.3	1.0	<0.3	1.0
Power Consumption (Watts)	5.6	12.2	6.9	13.5	8.0	15.5	11.6	20.0
Energy Efficiency (CFM/Watts)	8.9	4.0	10.1	5.0	11.2	5.6	11.2	6.2
Current (Amps)	0.44 Max							
Power Rating (V/Hz)	120/60							

SMT150 - 150 CFM Single Speed Exhaust Fan



Fan Speed	Continuous Low Speed	Full Speed
Static Pressure (Inches w.g.)	0.1	0.25
Air Flow (CFM)	150	149
Sones	<0.3	1.3
Power Consumption (Watts)	16.9	23.7
Energy Efficiency (CFM/Watts)	8.8	6.2
Current (Amps)	0.47 Max	
Power Rating (V/Hz)	120/60	

SMT150D - 0-110/150 CFM Fan with adjustable Dual Speed



Fan Speed	Continuous Low Speed						Full Speed	
Static Pressure (Inches w.g.)	0.1	0.25	0.1	0.25	0.1	0.25	0.1	0.25
Air Flow (CFM)	70	68	90	88	110	109	150	149
Sones	<0.3	1.0	<0.3	1.0	<0.3	1.0	<0.3	1.3
Power Consumption (Watts)	6.9	13.5	8.0	15.5	9.8	18.4	16.9	23.7
Energy Efficiency (CFM/Watts)	10.1	5.0	11.2	5.6	11.2	5.9	8.8	6.2
Current (Amps)	0.47 Max							
Power Rating (V/Hz)	120/60							

SMT150LED - 150 CFM Fan/Dimmable LED Light / Night-Light



Fan Speed	Continuous Low Speed	Full Speed
Static Pressure (Inches w.g.)	0.1	0.25
Air Flow (CFM)	150	150
Sones	0.5	1.3
Power Consumption (Watts)	17.6	25.4
Energy Efficiency (CFM/Watts)	8.5	5.9
Current (Amps)	0.62 Max	
Power Rating (V/Hz)	120/60	
LED Main Light (Watts/Lumens)	13/850	
LED Night Light (Watts)	2	

SMT150-200 - 150/200 CFM Fan



Fan Speed	Continuous Low Speed	Full Speed
Static Pressure (Inches w.g.)	0.1	0.25
Air Flow (CFM)	150	200
Sones	0.4	1.5
Power Consumption (Watts)	14.0	36.0
Energy Efficiency (CFM/Watts)	10.7	5.5
Current (Amps)	0.68 Max	
Power Rating (V/Hz)	120/60	

SMT150-200LED - 150/200 CFM Fan/Dimmable LED Light with adjustable color temperature



Fan Speed	Continuous Low Speed	Full Speed
Static Pressure (Inches w.g.)	0.1	0.25
Air Flow (CFM)	150	200
Sones	0.6	1.5
Power Consumption (Watts)	15.0	37.0
Energy Efficiency (CFM/Watts)	10.0	5.4
Current (Amps)	0.78 Max	
Power Rating (V/Hz)	120/60	
LED Light (Watts/Lumens)	13/850	

* Product is ENERGY STAR Most Efficient 2022 distinction and ENERGY STAR qualified

Smart SMT-CRD Ceiling Radiation Damper

The damper employs a folded curtain style blade for point-of-origin control of radiant heat in a ventilation system. SMT-CRD installs in the ceiling membrane for floor/ceiling or roof/ceiling assemblies with a fire resistance rating up to and including 3 hours.

Features:

- UL and cUL listed and exceeds UL 555C for use in 3-hour fire rated assemblies
- Warnock-Hersey certified for use in fire rated floor/ceiling or roof/ceiling assemblies
- CSFM listing: 3226-0368:104
- Meets NFPA Standards: 90A and 101
- Meets Building Code Standards: IBC, NBC, NFPA, SBC, and UBC
- Available Available for use with Delta Breez SMT130, SMT130M, SMT130H, SMT150, SMT150D, and SMT150LED (For combustible and non-combustible installation), SLM80, SLM100, SLM80-110-C, SLM80-110LED-C, SLM80-110D-C, and SLM80-110DLED-C (For non-combustible installation only).

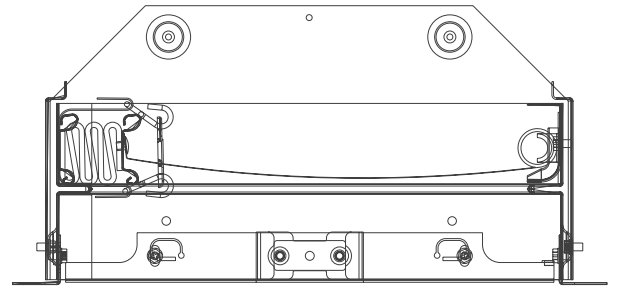
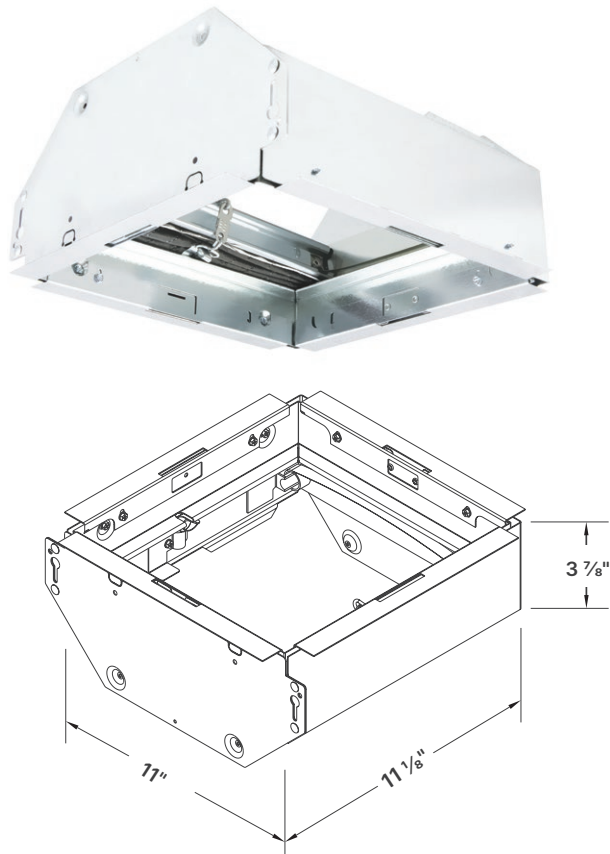

Smart SMT-MTL metal grille

The SMT-MTL metal grille is offered as an alternative to the standard grille on Delta Breez SMT130, SMT130H, SMT150, SMT150D, SMT150-200, SLM80 and SLM100.

Features:

- Adds modern aesthetic to bathroom
- Made of galvanized steel material and white painted
- Paintable for added customization
- Size: 13 × 13 × 3/8 inches

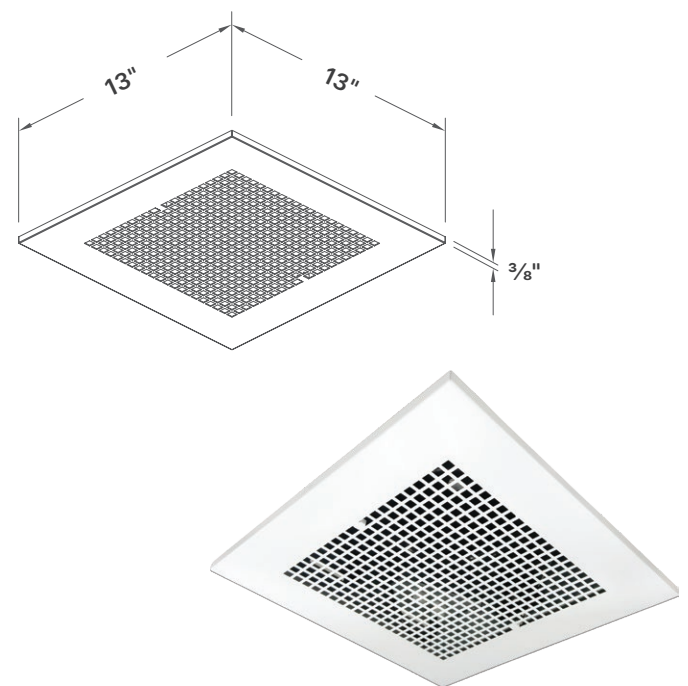



6 Inch Duct Series

Affordable performance, feature-rich with very quiet operation from 0.5 to 0.7 sones.

Innovative, pocket mounting brackets stay hidden and slide out for room-side installation in remodeling projects and for time-saving installation in new construction projects. A perfect solution where space is at a premium. High speed 80 or 110 CFM. For spaces 80-110 sq ft. Options include adjustable high and/or low speeds, dimmable LED light, motion and/or adjustable humidity sensor. Ceiling Radiation Damper available. UL listed for ceiling mount only.

Features:

- Innovative brushless DC motor design for long life, low noise, and low power consumption
- Energy savings up to 67.1%¹ and 6" duct (standard)
- Lowest sone level rated by HVI as low as 0.7 sones
- Adjustable wings for easy installation
- Power consumption down to 10.3 Watts
- Exceeds Energy Star energy efficiency requirements by 202%²
- Adjustable high speed of 80 or 110 CFM
- Dual speed, motion-sensing, and humidity-sensing options with continuous adjustable low-speed
- Includes 6" to 4" duct reducer
- Ceiling Radiation Damper available (fits GBR-CRD)

Fan/Dimmable LED Light:

- 13-Watt LED light output of 850 lumens, 3000K and 90 CRI
- Dimmable LED light (dimmer switch not included)

pocket mounting brackets stay hidden



pocket mounting brackets slide out



Adapter 4" duct



High Speed Switch

1. Based upon ELT80-110 vs. market AC motor with 6" duct.

2. Based upon ELT 110 CFM vs. ENERGY STAR v4.0 criteria for residential ventilating fans



BreezElite Series Dimensions

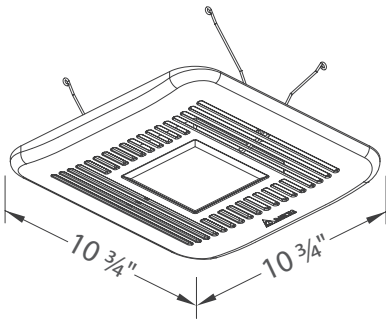
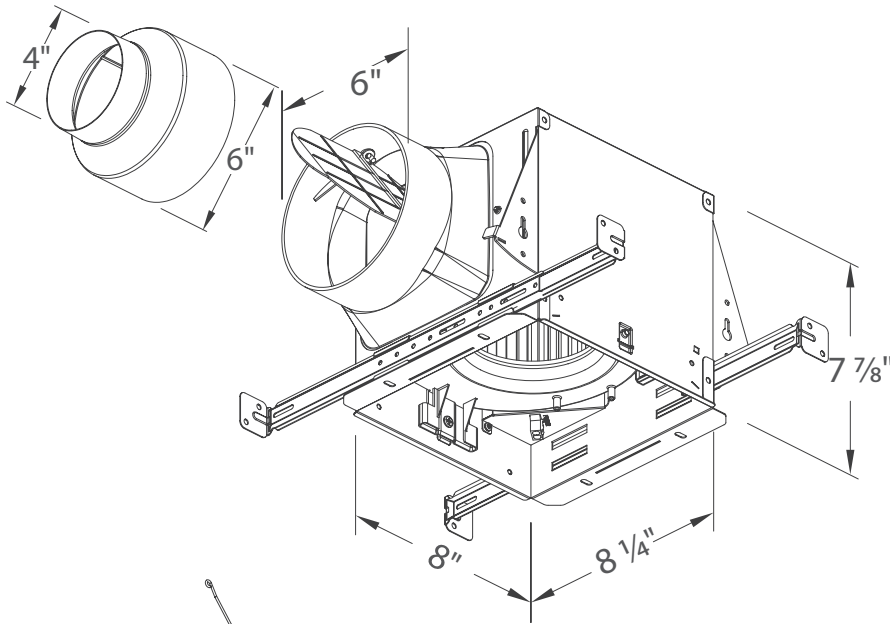

Fan/Dimmable LED Light Grille

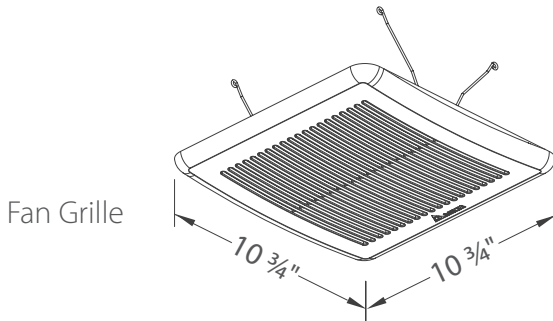

Fan Grille

Built-in Controls

ELT80-110H, ELT80-110HLED
ELT80-110MH, ELT80-110MHLED

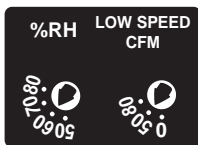

ELT80-110D
ELT80-110DLED

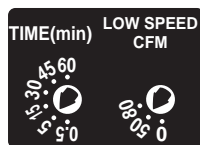

LED Indicator Light:

ELT80-110, ELT80-110LED

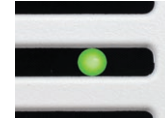

ELT80-110D, ELT80-110DLED

Low Speed

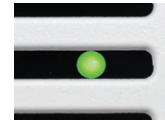

Full Speed

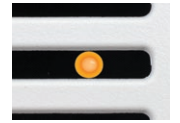

ELT80-110H, ELT80-110HLED,
ELT80-110MH & ELT80-110MHLED

Humidity Sensing

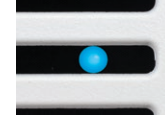

Full Speed

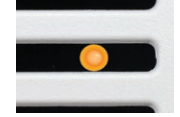

Specifications

ELT80-110 - 80/110 CFM Fan



Static Pressure (Inches w.g.)	0.1	0.25	0.1	0.25
Air Flow (CFM)	80	59	110	90
Sones	0.5	0.9	0.7	1.0
Power Consumption (Watts)	7	9	10.3	13
Energy Efficiency (CFM/Watts)	11.4	6.5	10.6	6.9
Current (Amps)	0.27 Max			
Power Rating (V/Hz)	120/60			

ELT80-110LED - 80/110 CFM Fan Fan/Dimmable LED Light



Static Pressure (Inches w.g.)	0.1	0.25	0.1	0.25
Air Flow (CFM)	80	59	110	89
Sones	0.5	0.9	0.7	1.0
Power Consumption (Watts)	7	9	10.3	13
Energy Efficiency (CFM/Watts)	11.4	6.5	10.6	6.8
Current (Amps)	0.28 Max			
Power Rating (V/Hz)	120/60			
LED Light (Watts/Lumens)	13/850			



Specifications (cont.)

ELT80-110D - 80/110 CFM Fan with Dual Speed



Fan Speed	Continuous Low Speed				Full Speed			
	0.1	0.25	0.1	0.25	0.1	0.25	0.1	0.25
Static Pressure (in w.g.)	0.1	0.25	0.1	0.25	0.1	0.25	0.1	0.25
Air Flow (CFM)	50	32	80	59	80	59	110	90
Sones	<0.3	0.8	0.5	0.9	0.5	0.9	0.7	1.0
Power (Watts)	5	6	7	9	7	9	10.3	13
Efficiency (CFM/Watts)	10	5.3	11.4	6.5	11.4	6.5	10.6	6.9
Current (Amps)	0.27 Max							
Power Rating (V/Hz)	120 / 60							

ELT80-110DLED - 80/110 CFM Fan Dimmable LED light w/ Dual Speed



Fan Speed	Continuous Low Speed				Full Speed			
	0.1	0.25	0.1	0.25	0.1	0.25	0.1	0.25
Static Pressure (in w.g.)	0.1	0.25	0.1	0.25	0.1	0.25	0.1	0.25
Air Flow (CFM)	50	35	80	59	80	59	110	89
Sones	0.3	0.8	0.5	0.9	0.5	0.9	0.7	1.0
Power (Watts)	5	6	7	9	7	9	10.3	13
Efficiency (CFM/Watts)	10.0	5.8	11.4	6.5	11.4	6.5	10.6	6.8
Current (Amps)	0.28 Max							
Power Rating (V/Hz)	120 / 60							
Light (Watts/Lumens)	13 / 850							

ELT80-110HLED - 80/110 CFM Fan/Dimmable LED Light with Humidity Sensor



Fan Speed	Continuous Low Speed				Full Speed			
	0.1	0.25	0.1	0.25	0.1	0.25	0.1	0.25
Static Pressure (in w.g.)	0.1	0.25	0.1	0.25	0.1	0.25	0.1	0.25
Air Flow (CFM)	50	35	80	59	80	59	110	89
Sones	0.3	0.8	0.5	0.9	0.5	0.9	0.7	1.0
Power (Watts)	5	6	7	9	7	9	10.3	13
Efficiency (CFM/Watts)	10	5.8	11.4	6.5	11.4	6.5	10.6	6.8
Current (Amps)	0.28 Max							
Power Rating (V/Hz)	120 / 60							
Light (Watts/Lumens)	13 / 850							

ELT80-110H - 80/110 CFM Fan with Humidity Sensor



Fan Speed	Continuous Low Speed				Full Speed			
	0.1	0.25	0.1	0.25	0.1	0.25	0.1	0.25
Static Pressure (in w.g.)	0.1	0.25	0.1	0.25	0.1	0.25	0.1	0.25
Air Flow (CFM)	50	32	80	59	80	59	110	90
Sones	<0.3	0.8	0.5	0.9	0.5	0.9	0.7	1.0
Power (Watts)	5	6	7	9	7	9	10.3	13
Efficiency (CFM/Watts)	10	5.3	11.4	6.5	11.4	6.5	10.6	6.9
Current (Amps)	0.27 Max							
Power Rating (V/Hz)	120 / 60							

ELT80-110MH - 80/110 CFM Fan w/ Motion and Humidity Sensor



Fan Speed	Continuous Low Speed				Full Speed			
	0.1	0.25	0.1	0.25	0.1	0.25	0.1	0.25
Static Pressure (in w.g.)	0.1	0.25	0.1	0.25	0.1	0.25	0.1	0.25
Air Flow (CFM)	50	32	80	59	80	59	110	90
Sones	<0.3	0.8	0.5	0.9	0.5	0.9	0.7	1.0
Power (Watts)	5	6	7	9	7	9	10.3	13
Efficiency (CFM/Watts)	10	5.3	11.4	6.5	11.4	6.5	10.6	6.9
Current (Amps)	0.27 Max							
Power Rating (V/Hz)	120 / 60							

ELT80-110MHLED - 80/110 CFM Fan/Dimmable LED Light w/ Motion and Humidity Sensor



Fan Speed	Continuous Low Speed				Full Speed			
	0.1	0.25	0.1	0.25	0.1	0.25	0.1	0.25
Static Pressure (in w.g.)	0.1	0.25	0.1	0.25	0.1	0.25	0.1	0.25
Air Flow (CFM)	50	35	80	59	80	59	110	89
Sones	0.3	0.8	0.5	0.9	0.5	0.9	0.7	1.0
Power (Watts)	5	6	7	9	7	9	10.3	13
Efficiency (CFM/Watts)	10	5.8	11.4	6.5	11.4	6.5	10.6	6.9
Current (Amps)	0.28 Max							
Power Rating (V/Hz)	120 / 60							
Light (Watts/Lumens)	13 / 850							

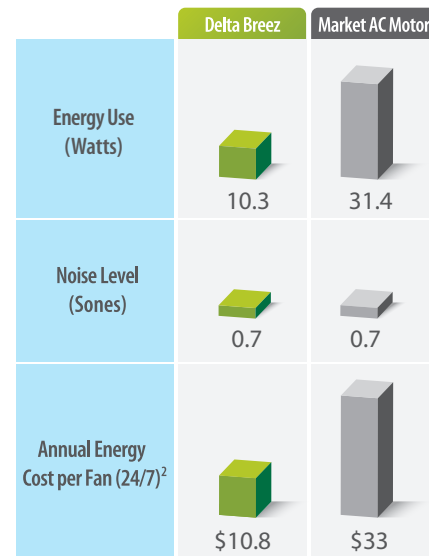

² Calculations based upon U.S. average retail electricity. Actual results may vary





4 Inch Duct Series

Designer fan solution

80 CFM fan disguised as a recessed light with Dimmable LED. For 80 sq. ft. space. Quiet operation at 1.5 sones. UL approved for ceiling mount only.

Features:

- ENERGY STAR qualified
- Brushless DC motor lasts 70,000 hours for extended reliability
- Quiet Operation at 1.5 sones

Fan/Dimmable LED Light:

- 13-Watt Dimmable LED light included (dimmer switch not included)
- LED main light output 850 lumens, 3000K, and 90 CRI

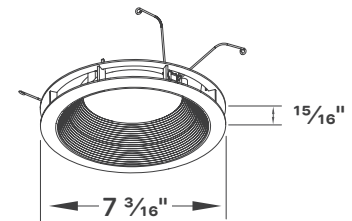
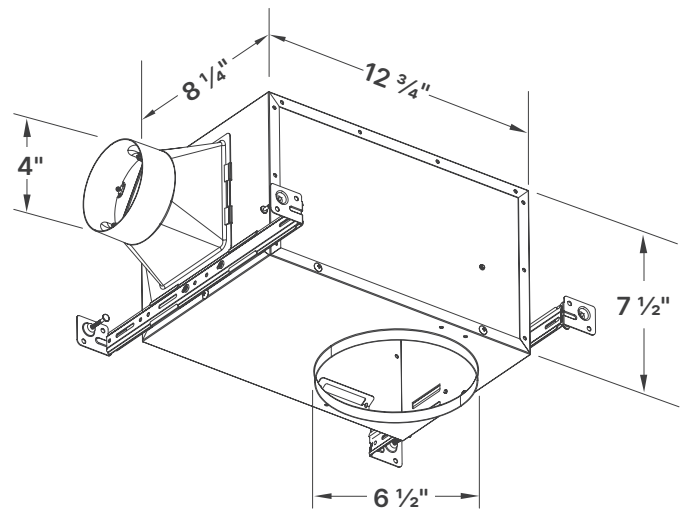

	Delta Breez	Market AC Motor
Energy Use (Watts)	14.5	34.4
Noise Level (Sones)	1.5	1.5
Annual Energy Cost per Fan (24/7) ¹	\$15.25	\$35.91

¹ Calculations based upon U.S. average retail electricity. Actual results may vary

Specifications

REC80LED - 80 CFM Fan/Dimmable LED Light  

Static Pressure (Inches w.g.)	0.1	0.25
Air Flow (CFM)	80	65
Sones	1.5	2.0
Power Consumption (Watts)	14.5	14.5
Energy Efficiency (CFM/Watts)	6.1	5.4
Current (Amps)	0.34 Max	
Power Rating (V/Hz)	120/60	
LED Light (Watts)	13	



4 Inch Oval Duct Series

The BreezSlim series of fans are suitable for ceiling or sidewall installation with high speed 80 or 110 CFM.

For spaces 80-110 sq. ft. Delta Breez Slim models offer a 4" metal oval duct adapter and easy installation for retrofit. Delta BreezSlim options include single speed, dimmable LED light, and/or dual speed. UL listed for wall and ceiling mount.

For SLM80-110 series with 4 side flange housing and available in contractor packs.

For SLM80-110-C series models can fit with Ceiling Radiation Damper SMT-CRD.

Features:

- Innovative brushless DC motor design for long life, low noise, and low power consumption
- Energy savings up to 72%¹ and 4" oval duct (standard)
- Exceeds ENERGY STAR requirement by 88% in energy efficiency²
- Annual energy cost for 24/7 operation is approximately \$8.94 (80 CFM) or \$17.35 (110 CFM)
- Noise level as low as 0.4 sones at 80 CFM, 1.2 sones at 110 CFM³
- Power consumption down to 16.5 Watts³
- Green and amber LED indicator lights show continuous low speed and full speed modes

Fan/Dimmable LED light:

- 13-Watt LED light output of 850 Lumens, 3000K and 90 CRI
- Dimmable LED Light (dimmer switch not included)

1. Based upon SLM80-110 vs. market AC motor.

2. Calculations based upon U.S. average retail electricity. Actual results may vary

3. Based upon SLM80-110



SLM80-110LED series Fan/Dimmable LED Light



SLM80-110 series

4 side flange

Project Pack Components Available



Built-in control

SLM80-110D, SLM80-110D-C
SLM80-110DLED, SLM80-110DLED-C

High Speed Switch

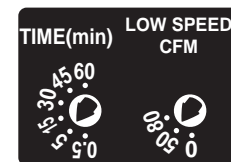



SLM80-110LED-C series
Fan/Dimmable LED Light

BreezSlim Series Dimensions

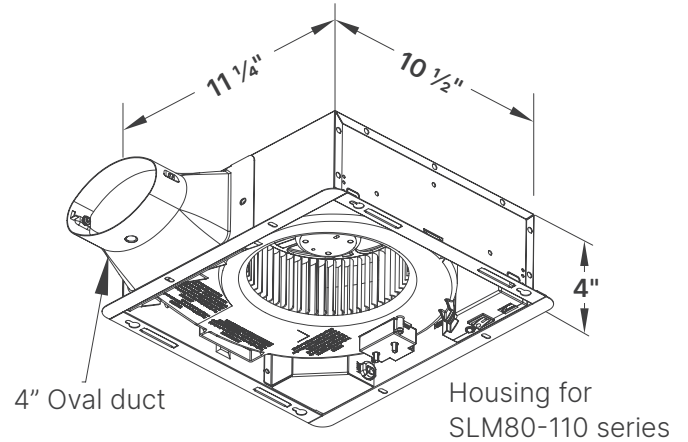

SLM80-110LED-C series

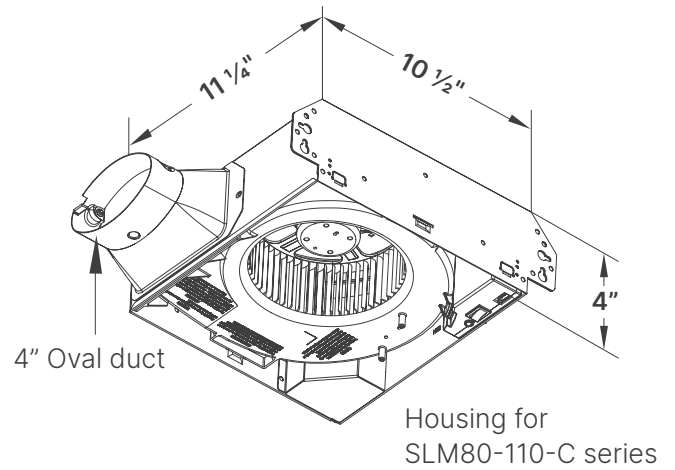

LED Indicator Light:

SLM80-110, SLM80-110-C
SLM80-110LED, SLM80-110LED-C

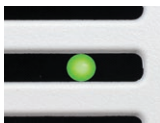

SLM80-110D,
SLM80-110D-C

Low Speed

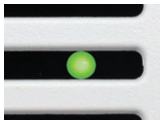

SLM80-110DLED
SLM80-110DLED-C

Full Speed

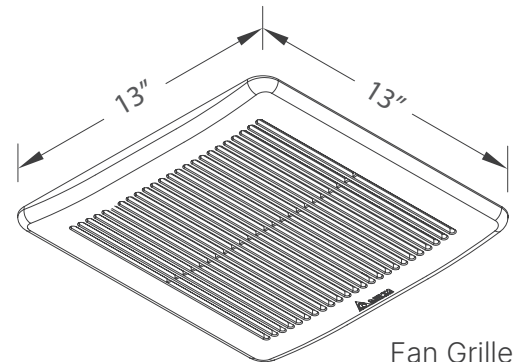
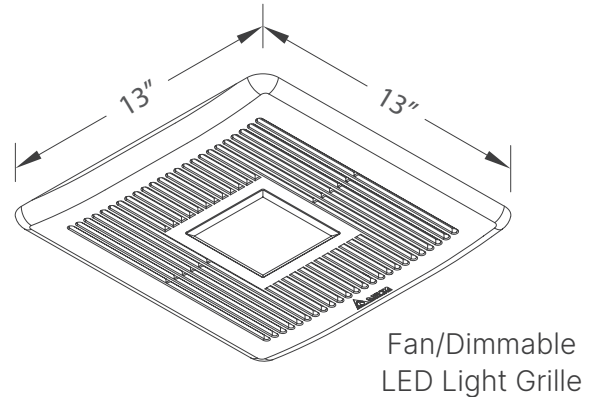
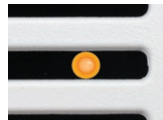



Specifications

SLM50-110-C - 50/80/110 CFM Exhaust Fan



	Full speed					
Static Pressure (Inches w.g.)	0.1	0.25	0.1	0.25	0.1	0.25
Air Flow (CFM)	50	50	80	80	110	110
Sones	<0.3	0.8	0.4	1.0	1.2	1.5
Power Consumption (Watts)	6	9.5	8.5	14.5	16.5	24
Energy Efficiency (CFM/Watts)	8.3	5.2	9.4	5.5	6.6	4.5
Current (Amps)	0.6 Max.					
Power Rating (V/Hz)	120/60					

SLM50-110LED-C - 50/80/110 CFM Fan/Dimmable LED Light with High Speed Adjustable



	Full speed					
Static Pressure (Inches w.g.)	0.1	0.25	0.1	0.25	0.1	0.25
Air Flow (CFM)	50	47	80	80	110	106
Sones	<0.3	0.8	0.4	1.1	1.3	1.5
Power Consumption (Watts)	6	9.5	9.0	14.5	16.5	24
Energy Efficiency (CFM/Watts)	8.3	4.9	8.8	5.5	6.6	4.4
Current (Amps)	0.6 Max.					
Power Rating (V/Hz)	120/60					
Dimmable LED Light (Watts)	13					

SLM80-110, SLM80-110-C 80/110 CFM Single Speed



	Full speed			
Static Pressure (Inches w.g.)	0.1	0.25	0.1	0.25
Air Flow (CFM)	80	80	110	110
Sones	0.4	1.0	1.2	1.5
Power Consumption (Watts)	8.5	14.5	16.5	24
Energy Efficiency (CFM/Watts)	9.4	5.5	6.6	4.5
Current (Amps)	0.6 Max.			
Power Rating (V/Hz)	120/60			

SLM80-110 Project Pack Components Available SLM-A3 (housing) and SLM80-110-B (motor and grille)

SLM80-110H-C, 80/110 CFM Fan with Humidity Sensor



	Continuous low speed				Full speed			
Static Pressure (Inches w.g.)	0.1	0.25	0.1	0.25	0.1	0.25	0.1	0.25
Air Flow (CFM)	50	50	80	80	80	80	110	110
Sones	<0.3	0.8	0.4	1.0	0.4	1.0	1.2	1.5
Power Consumption (Watts)	6	9.5	8.5	14.5	8.5	14.5	16.5	24
Energy (CFM/Watts)	8.3	5.2	9.4	5.5	9.4	5.5	6.6	4.5
Current (Amps)	0.6 Max.							
Power Rating (V/Hz)	120/60							

SLM80-110D, SLM80-110D-C, 80/110 CFM - Fan with Dual Speed



	Continuous low speed				Full speed			
Static Pressure (Inches w.g.)	0.1	0.25	0.1	0.25	0.1	0.25	0.1	0.25
Air Flow (CFM)	50	50	80	80	80	80	110	110
Sones	<0.3	0.8	0.4	1.0	0.4	1.0	1.2	1.5
Power Consumption (Watts)	6	9.5	8.5	14.5	8.5	14.5	16.5	24
Energy (CFM/Watts)	8.3	5.2	9.4	5.5	9.4	5.5	6.6	4.5
Current (Amps)	0.6 Max.							
Power Rating (V/Hz)	120/60							

SLM80-110LED, SLM80-110LED-C 80/110 CFM - Fan/Dimmable LED Light



	Full speed			
Static Pressure (Inches w.g.)	0.1	0.25	0.1	0.25
Air Flow (CFM)	80	80	110	106
Sones	0.4	1.1	1.3	1.5
Power Consumption (Watts)	9.0	14.5	16.5	24
Energy Efficiency (CFM/Watts)	8.8	5.5	6.6	4.4
Current (Amps)	0.6 Max.			
Power Rating (V/Hz)	120/60			
LED Light (Watts/Lumens)	13/850			

SLM80-110LED Project Pack Components Available SLMLED-A3 (housing) and SLM80-110LED-B (motor and LED grille)

SLM80-110DLED, SLM80-110DLED-C 80/110 CFM Fan/Dimmable LED Light with Dual Speed



	Continuous low speed				Full speed			
Static Pressure (Inches w.g.)	0.1	0.25	0.1	0.25	0.1	0.25	0.1	0.25
Air Flow (CFM)	50	47	80	80	80	80	110	106
Sones	<0.3	0.8	0.4	1.1	0.4	1.1	1.3	1.5
Power Consumption (Watts)	6	9.5	9.0	14.5	9.0	14.5	16.5	24
Energy Efficiency (CFM/Watts)	8.3	4.9	8.8	5.5	8.8	5.5	6.6	4.4
Current (Amps)	0.6 Max.							
Power Rating (V/Hz)	120/60							
Dimmable LED Light (Watts)	13/850							

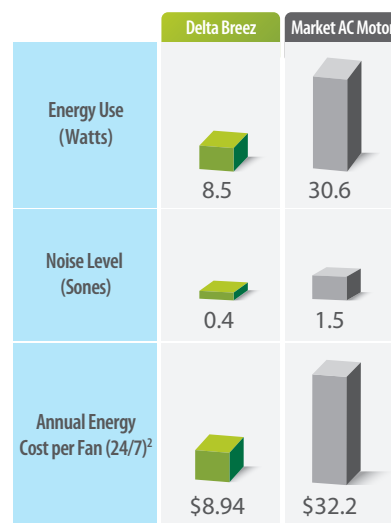

1. Based upon SLM80-110-C vs. market AC motor.

2. Calculations based upon U.S. average retail electricity. Actual results may vary



4 Inch Oval Duct Series

The BreezSlim series of fans are suitable for ceiling or sidewall installation.

All BreezSlim fans are ENERGY STAR qualified. Delta Breez SLM80 and SLM100 models offer a 4" metal oval duct adapter. As with all Delta Breez fans, BreezSlim series fans also feature an LED indicator light underneath the grille to show the user that this quiet fan is running. Available in contractor packs.

Features:

Slim design with innovative brushless DC motor design for long life, low noise, and low power consumption

- 4" Oval Duct:
 - Noise level as low as 1.2 sones
 - Annual energy cost for 24/7 operation is approximately \$8.94¹
- UL approved for ceiling and wall mount installation
- Ceiling Radiation Damper available (fits SMT-CRD)

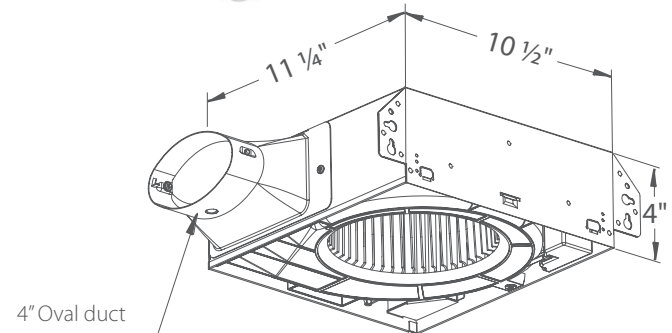

4" Oval duct

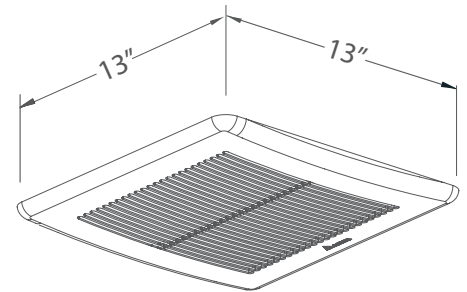

Fan Grille

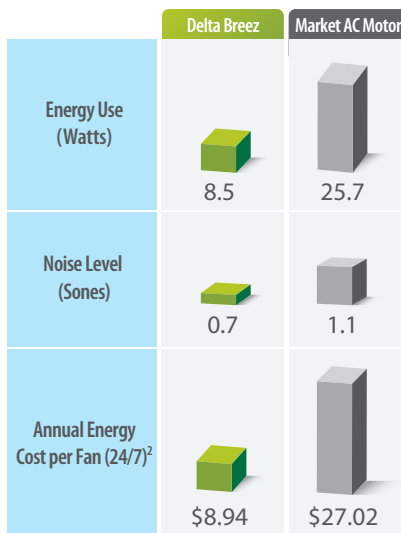

LED Indicator Light:
SLM80, SLM100



Specifications

SLM80 - 80 CFM Single Speed Exhaust Fan

	4" Oval duct	
Static Pressure (Inches w.g.)	0.1	0.25
Air Flow (CFM)	80	62
Sones	0.7	1.1
Power Consumption (Watts)	8.5	10.9
Energy Efficiency (CFM/Watts)	9.4	5.6
Current (Amps)	0.26 Max	
Power Rating (V/Hz)	120/60	
Project Pack Components Available SLM-A2 (housing) and SLM80-B (motor and grille)		

SLM100 - 100 CFM Single Speed Exhaust Fan

	4" Oval duct	
Static Pressure (Inches w.g.)	0.1	0.25
Air Flow (CFM)	100	84
Sones	1.0	1.5
Power Consumption (Watts)	14.5	17.7
Energy Efficiency (CFM/Watts)	6.8	4.7
Current (Amps)	0.3 Max	
Power Rating (V/Hz)	120/60	
Project Pack Components Available SLM-A2 (housing) and SLM100-B (motor and grille)		

1. Based upon SLM80 CFM vs. ENERGY STAR v4.0 criteria for residential ventilating fans
2. Calculations based upon U.S. average retail electricity. Actual results may vary





3 Inch Duct Series

Super Low Profile. Super Low Energy Consumption.

Weighing less than 5 lbs., the powerful and compact Delta BreezSlim sets the bar for performance in the popular small fan size of 7 1/2" x 7 1/4" x 4". Operating at just 1.0 sone, this quiet fan features Delta's super reliable brushless DC motor, an LED indicator light so you know it's running, and a modern grille design. Perfect for retrofit into an existing space or for ceiling mount or wall mount installation (UL listed for both) into your next multifamily or single-family project. BreezSlim breaks the mold of the everyday bathroom exhaust fan. Available in contractor packs.

Features:

Innovative brushless DC motor design for long life, low noise and low power consumption.

- Energy savings up to 85%¹ and 3" duct (standard)
- 1 sone – The quietest ever in a 7 1/2" x 7 1/4" bath fan
- Exceeds Energy Star energy efficiency requirements by 217%²
- UL listed for both ceiling-mount and wall-mount installation

1. Based upon SLM50 vs. market AC motor

2. Based upon ENERGY STAR v4.0 criteria for residential ventilating fans

	Delta Breez	Market AC Motor
Energy Use (Watts)	6.4	45.2
Noise Level (Sones)	1.0	4.0
Annual Energy Cost per Fan (24/7) ³	\$6.73	\$47.56

3. Calculations based upon U.S. average retail electricity. Actual results may vary



Available with Project Pack Components



Available with metal duct adapter

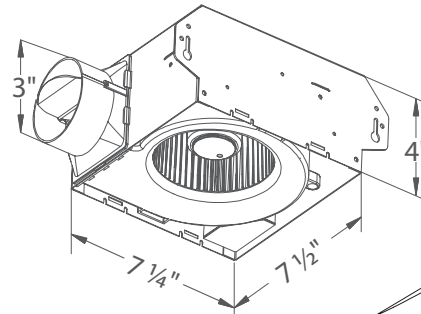

Fan Housing

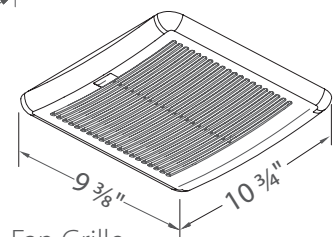

Fan Grille



LED Indicator Light: SLM50, SLM70

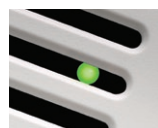

LED Indicator Light: SLM70D



LED Indicator Light: SLM70H



breez Slim

3 Inch Duct Series



SLM70ELED

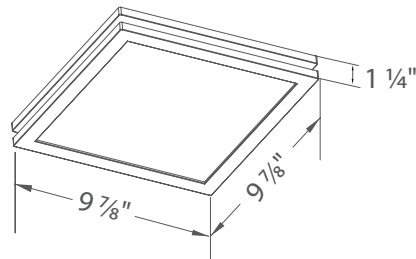

Specifications

SLM50* - 50 CFM Single Speed Exhaust Fan



3" Duct (Standard)		
Static Pressure (Inches w.g.)	0.1	0.25
Air Flow (CFM)	50	36
Sones	1.0	1.2
Power Consumption (Watts)	6.4	6.3
Energy Efficiency (CFM/Watts)	11.6	7.4
Current (Amps)	0.18 Max	
Power Rating (V/Hz)	120/60	
Project Pack Components Available SLM-A (housing) and SLM50-B (motor grille)		

SLM70 - 70 CFM Single Speed Exhaust Fan



3" Duct (Standard)		
Static Pressure (Inches w.g.)	0.1	0.25
Air Flow (CFM)	70	54
Sones	2.0	1.5
Power Consumption (Watts)	13.2	11.6
Energy Efficiency (CFM/Watts)	5.8	5.0
Current (Amps)	0.29 Max	
Power Rating (V/Hz)	120/60	
Project Pack Components Available SLM-A (housing) and SLM70-B (motor grille)		

* Product is ENERGY STAR Most Efficient 2022 distinction and ENERGY STAR qualified

SLM70H - 70 CFM Fan with Humidity sensor



3" Duct (Standard)		
Static Pressure (Inches w.g.)	0.1	0.25
Air Flow (CFM)	70	54
Sones	2.0	1.5
Power Consumption (Watts)	13.2	11.6
Energy Efficiency (CFM/Watts)	5.8	5.0
Current (Amps)	0.29 Max	
Power Rating (V/Hz)	120/60	
Project Pack Components Available SLM-A (housing) and SLM70H-B (motor grille)		

SLM70D - 70 CFM Fan with Dual Speed



	Continuous low speed		Full Speed	
	Static Pressure (Inches w.g.)	0.1	0.25	0.1
Air Flow (CFM)	40	25	70	50
Sones	0.8	1.0	2.0	1.5
Power Consumption (Watts)	5.0	6.0	13.2	11.6
Energy Efficiency (CFM/Watts)	12.9	6.3	7.1	6.2
Current (Amps)	0.29 Max			
Power Rating (V/Hz)	120/60			

SLM70ELED - 70 CFM Fan Edge-Lit Dimmable LED Light



3" Duct (Standard)		
Static Pressure (Inches w.g.)	0.1	0.25
Air Flow (CFM)	70	53
Sones	2.0	1.5
Power Consumption (Watts)	13.2	11.6
Energy Efficiency (CFM/Watts)	6.0	5.4
Current (Amps)	0.29 Max	
Power Rating (V/Hz)	120/60	
LED Light (Watts/Lumens)	13/850	

Delta BreezSignature SLM-DGL Designer Grille

The SLM-DGL designer fan grille is offered as an alternative to the standard grille on Delta Breez SLM50, SLM70, SLM70H, ITG50, ITG80, ITG70BT, ITG80H, and ITG100.

Features:

- Adds modern aesthetic to bathroom
- Made of long-lasting ABS material
- Paintable to coordinate with any style bathroom
- Size: 10 3/4" x 10 3/4"

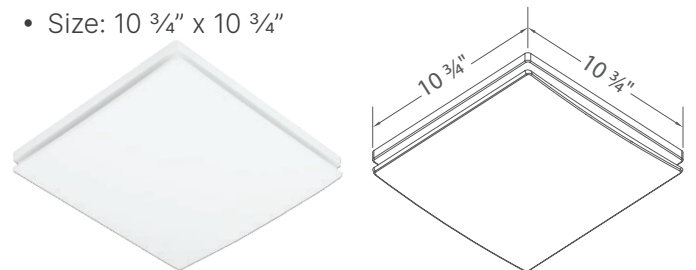



FRESHNESS IN THE AIR

CONTINUOUS AIRFLOW BY PRESSURIZED DESIGN

Delta Breez Fresh Air Supply Fan

Meet The New Delta BreezFresh Supply Air Fan: FRS200

When it comes to efficiency and versatility, Delta BreezFresh FRS200 is the industry's best. First, it is the most energy-efficient Supply Air Fan (SAF) on the market, delivering more CFM/watt than competitor products. It is not only Energy Star rated, but it also exceeds Energy Star Most Efficient requirements by 20%. The FRS200 is also the most versatile SAF, offering the widest CFM range from 30 to 200CFM. Which means it can meet the ventilation codes for homes from a 1-bedroom apartment to a 5-bedroom 5,000 ft² home.

The Delta BreezFresh FRS200 is also uniquely designed to meet three ventilation functions, Supply, Balanced, and Purification. As a fresh air Supply fan, the FRS200, combined with the optional MERV13 filter, removes outdoor pollutants from the incoming air, reducing allergens, odors, and disease spread. When combined with a DeltaBreez bathroom exhaust fan, the FRS200 creates a balanced ventilation system, which reduces positive or negative pressures inside the home. As an air Purification system, FRS200 and the optional MERV13 filter remove pollutants, such as dust, pet dander, and virus particles from indoor air, then delivers purified air back to the home. The FRS200 creates healthier air using less energy in a larger variety of homes.

Features:

- Innovative brushless DC motor design for long life, low noise, and low power consumption
- Energy savings up to 72% and 6" round duct (standard)
- Five mounting installation possibilities: ceiling hung, under ceiling, wall mounted, attic mounted, and flush to ceiling
- Easy installation with bracket
- UL/cUL listed
- ECM motor engineered to run continuously for a minimum 70,000 hours
- Insulated housing reduces noise and condensation
- Removable permanently lubricated motor
- Built-in soft start function to increase bearing life
- Automatically powers OFF when impeller is locked abnormally



6 Inch Duct Series

The fresh air supply fan rated for 30 to 200 CFM, which offers quiet energy efficient operation.

The Delta BreezFresh FRS200 is a fresh air supply fan rated for 30 to 200 CFM, which offers quiet energy efficient operation. It is not just ENERGY STAR rated, it exceeds Energy Star Most Efficient requirements by over 20%. Energy Star Most Efficient recognizes the top ENERGY STAR labeled products.

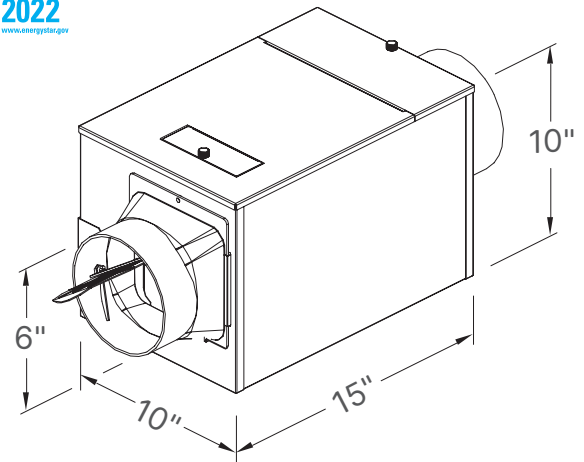
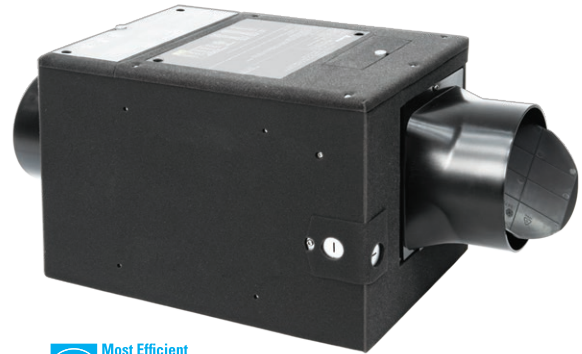

BreezFresh FRS200	6" Duct (standard)
Height Length	15"
Ports diameter Width	10"
Height	10"
Ports diameter	6"
Operating Temperature	14° F ~ 104° F

FRS200 (VDBFRS200) - Supply Fan

Static Pressure (inch w.g.)	0.2									
	Air Flow (CFM)	200	170	150	130	110	90	70	50	40
Power Consumption (Watts)	42.0	29.3	22.7	19.1	14.1	11.4	8.5	7.2	6.1	5.2
Energy Efficiency (CFM/Watts)	4.8	5.8	6.6	6.8	7.8	7.9	8.2	7.0	6.6	5.8
Static Pressure (inch w.g.)	0.4									
	Air Flow (CFM)	160	160	150	130	110	90	70	50	40
Power Consumption (Watts)	35.2	35.2	33.6	27.7	21.7	17.7	12.8	11.8	9.8	9.0
Energy Efficiency (CFM/Watts)	4.6	4.6	4.6	4.7	5.1	5.1	5.5	4.2	4.1	3.2

Performance with pre-filter & MERV 13 filter installed

FRS200 (VDBFRS200) - Supply Fan

Static Pressure (inch w.g.)	0.2									
	Air Flow (CFM)	200	170	150	130	110	90	70	50	40
Power Consumption (Watts)	33.0	23.5	18.8	16.2	11.7	10.0	8.0	6.3	5.4	4.7
Energy Efficiency (CFM/Watts)	6.0	7.2	7.9	8.0	9.4	9.0	8.8	7.9	7.4	6.4
Static Pressure (inch w.g.)	0.4									
	Air Flow (CFM)	197	170	150	129	110	90	70	47	40
Power Consumption (Watts)	42.0	34.9	29.0	22.5	19.5	15.9	13.0	10.5	9.2	8.5
Energy Efficiency (CFM/Watts)	4.7	4.9	5.2	5.7	5.6	5.7	5.3	4.5	4.4	3.5

Performance with pre-filter installed



4 Inch Duct Series

Builder's best solution

Delta BreezGreenBuilder ventilation fans were designed with green builders and contractors in mind. High speed 80 CFM or 100 CFM. For spaces 80-100 sq. ft. Quiet operation from 0.8 to 1.4 sones. Options include adjustable low speed, dimmable LED light, and decorative dimmable LED light, motion and/or humidity sensor. Ceiling Radiation Damper and designer grille available separately. Fan only and fans with humidity sensor are UL listed for ceiling and wall mount; Fans w/ LED light are UL listed for ceiling mount only.

Features:

Innovative brushless DC motor design for long life, low noise and low power consumption

- Energy savings up to 61%¹ and 4" duct (standard)
- Lowest sone level rated by HVI as low as 0.8 sones
- Power consumption as low as 10.5 Watts
- Exceeds ENERGY STAR requirements by 192% in energy efficiency²
- Fan and Fan/dimmable LED Light combination project pack available
- Fan only models are UL listed for both ceiling-mount and wall-mount installation

Fan/Dimmable LED Light:

- 13-Watt Dimmable LED light included (60 watt equivalent). Dimmer switch not included
- Main light output of 850 lumens, 3000K and 90 CRI

Fan/Dimmable LED Light DECOR:

- 13-Watt Dimmable LED light included. Dimmer switch not included.
- Main light output of 950 Lumens, 3000K and 80 CRI
- Beautifully designed ventilation fan with frosted glass globe and dimmable LED light allows for quiet ventilation
- 4-decorative fans in one; includes chrome, brushed nickel, brushed bronze, and polished white finials to match any décor



Fan Only



Fan/Dimmable LED Light



GBR100LED-DECOR



Project Pack Components Available

1. Based on GreenBuilder GBR80 vs. market AC motor fan

2. Based upon GBR80CFM vs. ENERGY STAR v4.0 criteria for residential ventilating fans



BreezGreenBuilder Series Dimensions

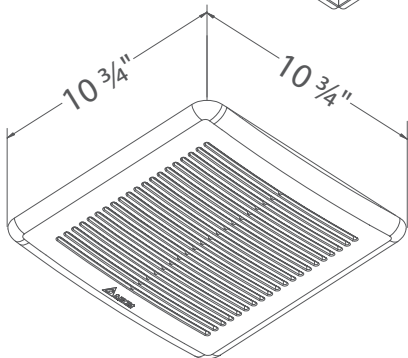
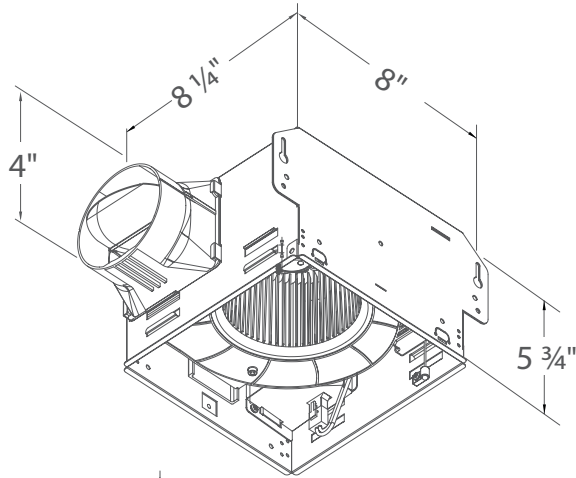

Grille for Fan Only

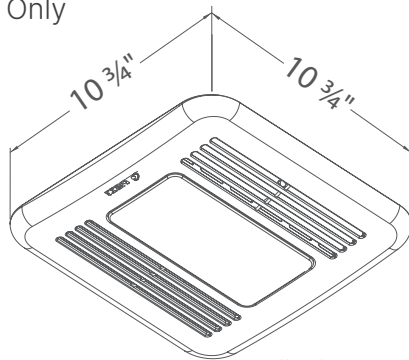

Grille for Fan/
Dimmable LED Light

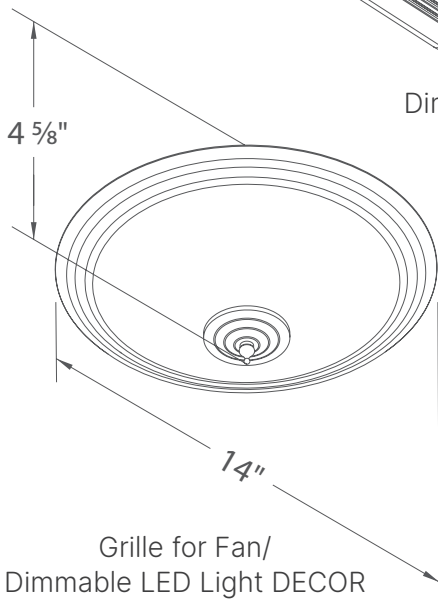

Grille for Fan/
Dimmable LED Light DECOR

LED Indicator Light:
GBR80, GBR80LED
GBR100, GBR100LED

LED Indicator Light:
GBR80H, GBR100H

Fan is running



Humidity Sensing Full Speed

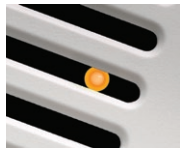

Built-in Controls

GBR80H, GBR80HLED

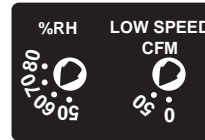

Built-in Controls

GBR100H

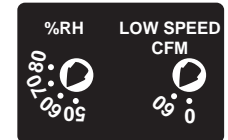

Specifications

GBR80 - 80 CFM Single Speed Exhaust Fan



Static Pressure (Inches w.g.)	0.1	0.25
Air Flow (CFM)	80	64
Sones	0.8	1.5
Power Consumption (Watts)	10.5	12.5
Energy Efficiency (CFM/Watts)	7.6	5.1
Current (Amps)	0.21 Max	
Power Rating (V/Hz)	120/60	
Project Pack Components Available GBR-A (housing) and GBR80-B (motor/grille)		

GBR80H - 80 CFM Fan with Humidity Sensor



Fan Speed	Continuous Low Speed		Full Speed	
	0.1	0.25	0.1	0.25
Static Pressure (Inches w.g.)	0.1	0.25	0.1	0.25
Air Flow (CFM)	50	35	80	64
Sones	<0.3	1.0	0.8	1.5
Power Consumption (Watts)	4.0	6.0	9.7	11.8
Energy Efficiency (CFM/Watts)	12.5	5.8	8.2	5.4
Current (Amps)	0.22 Max			
Power Rating (V/Hz)	120/60			

GBR80HLED - 80 CFM Fan Dimmable LED Light with Humidity Sensor



Fan Speed	Continuous Low Speed		Full Speed	
	0.1	0.25	0.1	0.25
Static Pressure (Inches w.g.)	0.1	0.25	0.1	0.25
Air Flow (CFM)	50	33	80	63
Sones	0.5	1.0	0.8	1.5
Power Consumption (Watts)	4.4	6.0	11.0	13.0
Energy Efficiency (CFM/Watts)	11.3	5.5	7.2	4.8
Current (Amps)	0.33 Max			
Power Rating (V/Hz)	120/60			
LED Light (Watts/Lumens)	13/850			



4 Inch Duct Series Specifications

GBR80LED - 80 CFM Fan/Dimmable LED Light



Static Pressure (Inches w.g.)	0.1	0.25
Air Flow (CFM)	80	63
Sones	0.8	1.5
Power Consumption (Watts)	11.0	13.0
Energy Efficiency (CFM/Watts)	7.2	4.8
Current (Amps)	0.33 Max	
Power Rating (V/Hz)	120/60	
LED Light (Watts/Lumens)	13/850	

GBR100 - 100 CFM Single Speed Exhaust Fan



Static Pressure (Inches w.g.)	0.1	0.25
Air Flow (CFM)	100	77
Sones	1.4	1.5
Power Consumption (Watts)	12.6	13.5
Energy Efficiency (CFM/Watts)	7.9	5.7
Current (Amps)	0.22 Max	
Power Rating (V/Hz)	120/60	

Project Pack Components Available GBR-A (housing) and GBR100-B (motor/grille)

GBR100H - 100 CFM Fan with Humidity Sensor



Fan Speed	Continuous Low Speed		Full Speed	
Static Pressure (Inches w.g.)	0.1	0.25	0.1	0.25
Air Flow (CFM)	60	42	100	77
Sones	0.5	0.7	1.4	1.5
Power Consumption (Watts)	4.9	6.3	12.6	13.5
Energy Efficiency (CFM/Watts)	12.2	6.6	7.9	5.7
Current (Amps)	0.24 Max			
Power Rating (V/Hz)	120/60			

GBR100LED - 100 CFM Fan/Dimmable LED Light



Static Pressure (Inches w.g.)	0.1	0.25
Air Flow (CFM)	100	72
Sones	1.5	1.5
Power Consumption (Watts)	13.6	11.6
Energy Efficiency (CFM/Watts)	7.3	6.2
Current (Amps)	0.35 Max	
Power Rating (V/Hz)	120/60	
LED Light (Watts/Lumens)	13/850	

GBR100LED-DECOR - 100 CFM Fan/Dimmable LED Light Decor



Static Pressure (Inches w.g.)	0.1	0.25
Air Flow (CFM)	100	72
Sones	1.5	2.0
Power Consumption (Watts)	13	12.5
Energy Efficiency (CFM/Watts)	7.6	5.7
Current (Amps)	0.32 Max	
Power Rating (V/Hz)	120/60	
LED Light (Watts/Lumens)	13/950	

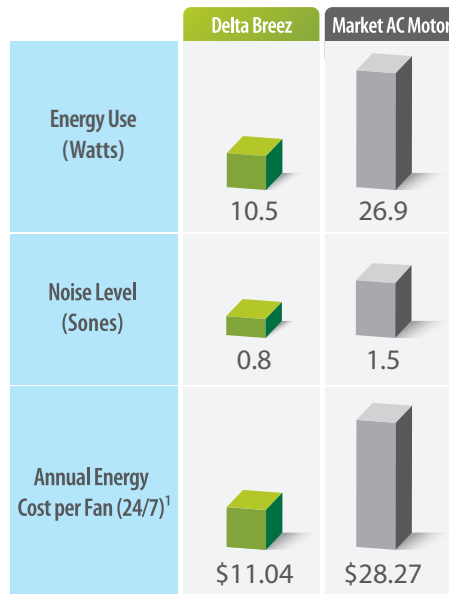

1. Calculations based upon U.S. average retail electricity. Actual results may vary

GreenBuilder GBR-DGL Designer Grille

The GBR-DGL designer fan grille is offered as an alternative to the standard grille on GBR80, GBR80H, GBR100, and GBR100H.

Features:

- Adds modern aesthetics to the bathroom
- Made of long-lasting ABS material
- Paintable to coordinate with any style bathroom
- Size: 10 3/4" x 10 3/4"

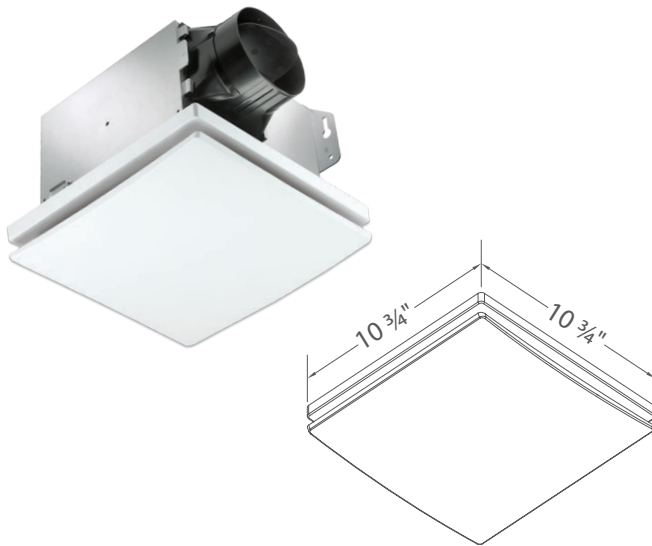

- Available for Delta Breez Ventilation Fans: GBR80, GBR80H, GBR80HLED, GBR80LED, GBR100, GBR100H and GBR100LED

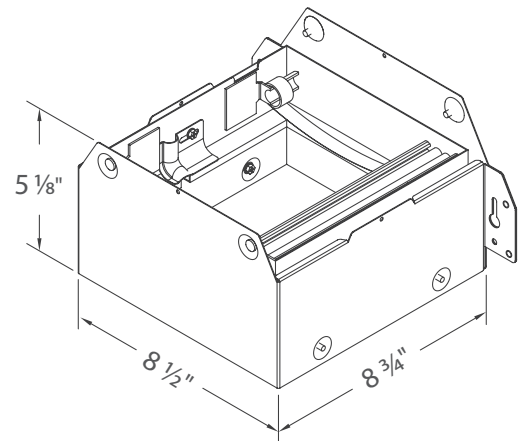
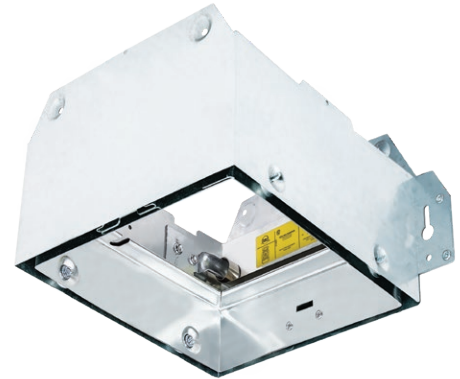

Delta BreezGreenBuilder GBR-CRD Ceiling Radiation Damper

The damper employs a folded curtain style blade for point-of-origin control of radiant heat in a ventilation system. GBR-CRD installs in the ceiling membrane for floor/ceiling or roof/ceiling assemblies with a fire resistance rating up to and including 3 hours.

Features:

- UL and cUL listed and exceeds UL 555C for use in 3-hour fire rated assemblies
- Warnock-Hersey certified for use in fire rated floor/ceiling or roof/ceiling assemblies
- CSFM listing: 3226-0368:104
- Meets NFPA Standards: 90A and 101
- Meets Building Code Standards: IBC, NBC, NFPA, SBC and UBC

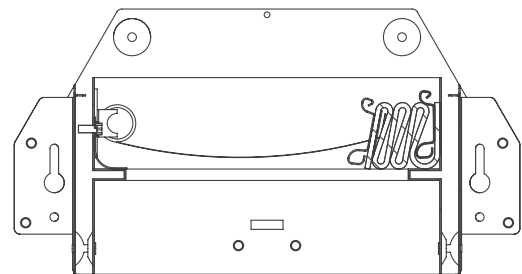



4 Inch Duct Series

Economical ventilation solution

Single speed 50, 80, or 100 CFM. For spaces 50-100 sq. ft. Quiet operation from 0.7 to 1.5 sones. Options include dimmable LED light or edge-lit dimmable LED light, adjustable humidity sensor, Bluetooth® speaker. Ceiling Radiation Damper and designer grille available separately. Fans only and fan with humidity sensor are UL listed for ceiling and wall mount; fans/dimmable LED light are UL listed for ceiling mount only.

Features:

Innovative brushless DC motor design for long life, low noise and low power consumption

- Power rating of 120 volts/60Hz
- Brushless DC motor engineered to run continuously
- Motor equipped with thermal cutoff fuse
- Removable with permanently lubricated plug-in motor
- Built-in soft start function to increase bearings' life
- Automatically powers off when impeller is locked abnormally

Fan/Dimmable LED Light:

- 13-Watt LED light included (equivalent to a 60-Watt incandescent bulb)
- Main light output of 850 lumens, 3000K and 90 CRI
- Dimmable LED light. Dimmer switch not included.

Fan/Edge-lit Dimmable LED Light:

- 13-Watt LED light
- Main light output of 1000 lumens, 3000K, and 80 CRI
- Dimmable LED light. Dimmer switch not included.
- 13-Watt integrated dimmable edge-lit LED light lasts up to 30,000 hours

Bluetooth® Speaker:

- Bluetooth® 3.0, speaker 3W and 4 Ohm
- Play audio through most Bluetooth® wireless devices



Fan Only



Fan with Bluetooth® speaker



Fan/Dimmable LED light

The Bluetooth® word mark and logos are registered trademarks owned by Bluetooth® SIG, Inc. and any use of such marks by Delta Electronics, Inc. is under license. Other trademarks and trade names are those of their respective owners.





Fan/Edge-lit
Dimmable LED light

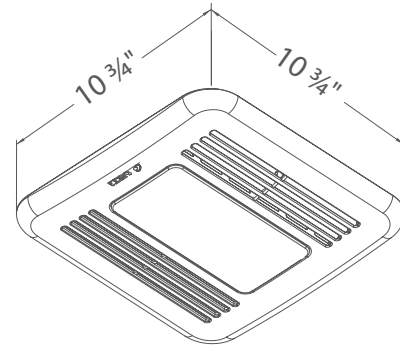

Grille for Fan/LED Light



Fan/LED Edge-Lit Dimmable LED light,
Flat Round Panel

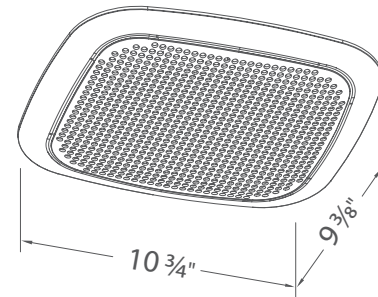

Grille for Fan with Bluetooth® Speaker

BreezIntegrity Series Dimensions

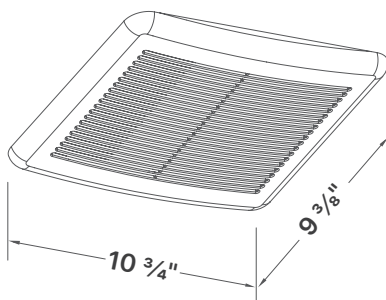
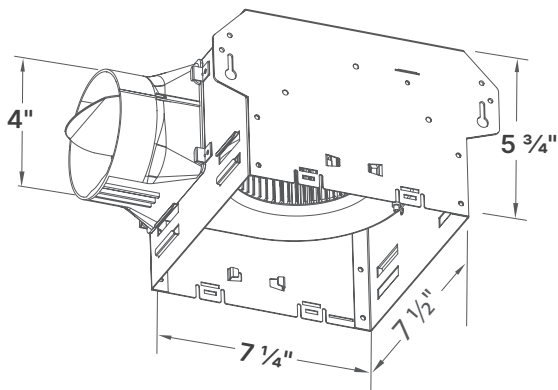

Grille for Fan Only

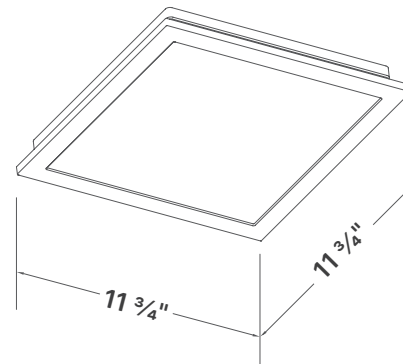

Grille for Fan/Edge-lit LED Light

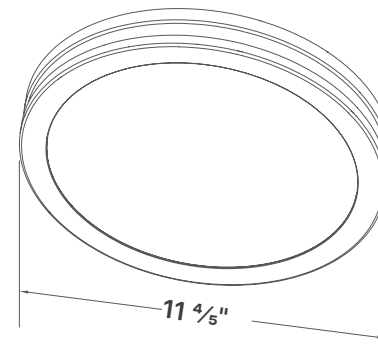

Grille for Fan/Edge-lit LED Light
Flat Round Panel



LED Indicator Light:

ITG80H, ITG50HLED

Humidity Sensing Full Speed



ITG80H Controls

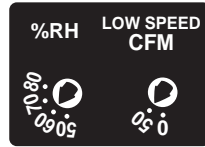

Project Pack Components Available



Specifications

ITG50* - 50 CFM Fan



Static Pressure (Inches w.g.)	0.1	0.25
Air Flow (CFM)	50	37
Sones	0.7	1.3
Power Consumption (Watts)	5.0	7.0
Energy Efficiency (CFM/Watts)	12.5	6.7
Current (Amps)	0.14 Max	
Power Rating (V/Hz)	120/60	

Project Pack Components Available ITG-A (housing) and ITG50-B (motor grille)

ITG50LED* - 50 CFM

Fan/Dimmable LED Light



Static Pressure (Inches w.g.)	0.1	0.25
Air Flow (CFM)	50	38
Sones	0.7	1.3
Power Consumption (Watts)	5.0	7.0
Energy Efficiency (CFM/Watts)	11	6.5
Current (Amps)	0.22 Max	
Power Rating (V/Hz)	120/60	
LED Light (Watts/Lumens)	13/850	

* Product is ENERGY STAR Most Efficient 2022 distinction and ENERGY STAR qualified

ITG70BT* - 70 CFM Fan w/ Bluetooth® Speaker



Static Pressure (Inches w.g.)	0.1	0.25
Air Flow (CFM)	70	59
Sones	1.0	1.5
Power Consumption (Watts)	6.6	8.3
Energy Efficiency (CFM/Watts)	10.7	7.2
Current (Amps)	0.2 Max	
Power Rating (V/Hz)	120/60	

ITG80 - 80 CFM Single Speed Exhaust Fan



Static Pressure (Inches w.g.)	0.1	0.25
Air Flow (CFM)	80	60
Sones	1.3	1.4
Power Consumption (Watts)	10.0	12.0
Energy Efficiency (CFM/Watts)	8.4	6.6
Current (Amps)	0.20 Max	
Power Rating (V/Hz)	120/60	

Project Pack Components Available ITG-A (housing) and ITG80-B (motor grille)

ITG80RLED-ADJ - 80 CFM Fan/LED Edge-Lit Flat Round Panel with Adjustable Color Temperature



Static Pressure (Inches w.g.)	0.1	0.25
Air Flow (CFM)	80	56
Sones	1.5	1.5
Power Consumption (Watts)	11.5	11.5
Energy Efficiency (CFM/Watts)	7.2	6.2
Current (Amps)	0.14 Max	
Power Rating (V/Hz)	120/60	
LED Light (Watts/Lumens)	13/1000	

ITG80H - 80 CFM Fan with Humidity Sensor



Fan Speed	Continuous Low Speed		Full Speed	
Static Pressure (Inches w.g.)	0.1	0.25	0.1	0.25
Air Flow (CFM)	50	36	80	60
Sones	0.7	1.0	1.5	1.5
Power Consumption (Watts)	5.0	7.0	10.0	12.0
Energy Efficiency (CFM/Watts)	12.0	6.9	9.0	6.2
Current (Amps)	0.20 Max			
Power Rating (V/Hz)	120/60			

Delta BreezIntegrity ITG-CRD Ceiling Radiation Damper

The damper employs a folded curtain style blade for Point-of-origin control of radiant heat in a ventilation system. ITG-CRD installs in the ceiling membrane for floor/ceiling or roof/ceiling assemblies with a fire resistance rating up to and including 3 hours.

Features:

- UL and cUL listed and exceeds UL 555C for use in 3-hour fire rated assemblies
- Warnock-Hersey certified for use in fire rated floor/ceiling or roof/ceiling assemblies
- Available for use with Delta Breez ventilation fans ITG100, ITG80, ITG50, ITG80H, ITG80LED, and ITG50LED.

ITG80LED - 80 CFM Fan/ Dimmable LED Light



Static Pressure (Inches w.g.)	0.1	0.25
Air Flow (CFM)	80	60
Sones	1.3	1.3
Power Consumption (Watts)	11.3	11.5
Energy Efficiency (CFM/Watts)	7.2	6.2
Current (Amps)	0.14 Max	
Power Rating (V/Hz)	120/60	
LED Light (Watts/Lumens)	13/850	

ITG100 - 100 CFM Single Speed Exhaust Fan



Static Pressure (Inches w.g.)	0.1	0.25
Air Flow (CFM)	100	85
Sones	1.5	2.0
Power Consumption (Watts)	17.0	21.0
Energy Efficiency (CFM/Watts)	7.6	5.3
Current (Amps)	0.33 Max	
Power Rating (V/Hz)	120/60	

Project Pack Components Available ITG-A2 (housing) and ITG100-B (motor grille)

ITG100ELED - 100 CFM Fan Edge-lit Dimmable LED Light



Static Pressure (Inches w.g.)	0.1	0.25
Air Flow (CFM)	100	85
Sones	1.5	2.0
Power Consumption (Watts)	17.0	21.0
Energy Efficiency (CFM/Watts)	7.5	5.9
Current (Amps)	0.47 Max	
Power Rating (V/Hz)	120/60	
LED Light (Watts/Lumens)	13/1000	

ITG100RLED - 100 CFM Fan LED Edge-lit, Flat Round Panel



Static Pressure (Inches w.g.)	0.1	0.25
Air Flow (CFM)	100	85
Sones	1.5	2.0
Power Consumption (Watts)	17.0	21.0
Energy Efficiency (CFM/Watts)	7.5	5.9
Current (Amps)	0.47 Max	
Power Rating (V/Hz)	120/60	
LED Light (Watts/Lumens)	13/1000	

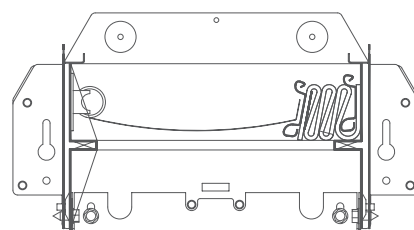
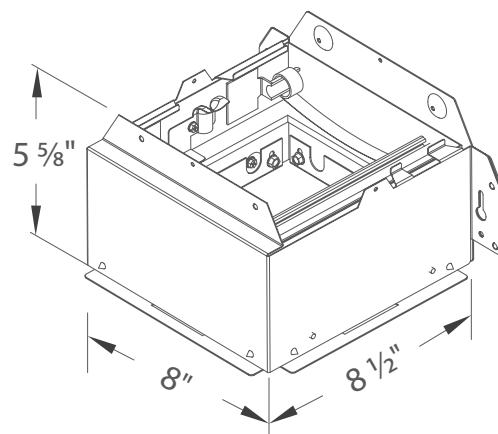



4 Inch Duct Series

Fan/heater solution to warm and delight.

Quiet operation from 0.7 to 1.5 sones. 80 or 110 CFM for spaces 80-110 sq. ft. Options include dimmable LED or fan/heater only. Built-in thermostat to regulate room temperature for maximum comfort. UL approved for ceiling mount only. Not UL approved for mounting over bathtub or shower.

Features:

- Energy saving DC motor technology
- Built-in thermostat for consistent temperature
- Metal guard to prevent user contact with heating element
- Heater module equipped with thermal cut off fuse
- Duct diameter of 4"
- 1300/1600 Watts heating element evaluated by cUL for safety standards

Fan/LED Light:

- 13-Watt LED lamp included (equivalent to a 60-Watt incandescent bulb)
- Main light output of 850 lumens, 3000K and 90 CRI
- Dimmable LED Light (dimmer switch not included)



RAD80 Fan with Heater

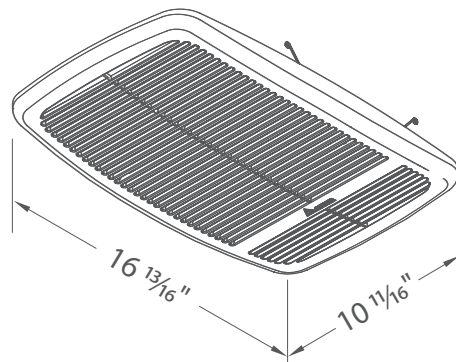
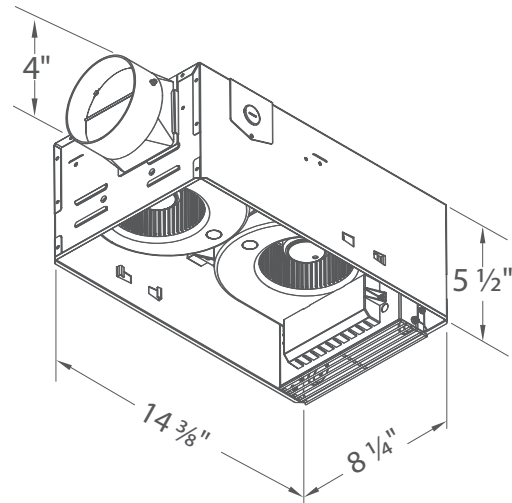

Built-in thermostat

	Delta Breez	Market AC Motor
Energy Use (Watts)	11.7	58
Noise Level (Sones)	1.5	4.0
Annual Energy Cost per Fan (24/7) ¹	\$12.31	\$60.54

¹ Calculations based upon U.S. average retail electricity. Actual results may vary

Specifications

RAD80 - 80 CFM Fan with Heater



Static Pressure (Inches w.g.)	0.1
Air Flow (CFM)	80
Sones	1.5
Power Consumption (Watts)	11.7
Energy Efficiency (CFM/Watts)	7.0
Current (Amps)	11
Power Rating (V/Hz)	120/60
Heating element (Watts)	1300
Total power (Watts)	1314



RAD80LED Fan/Dimmable LED Light/Heater

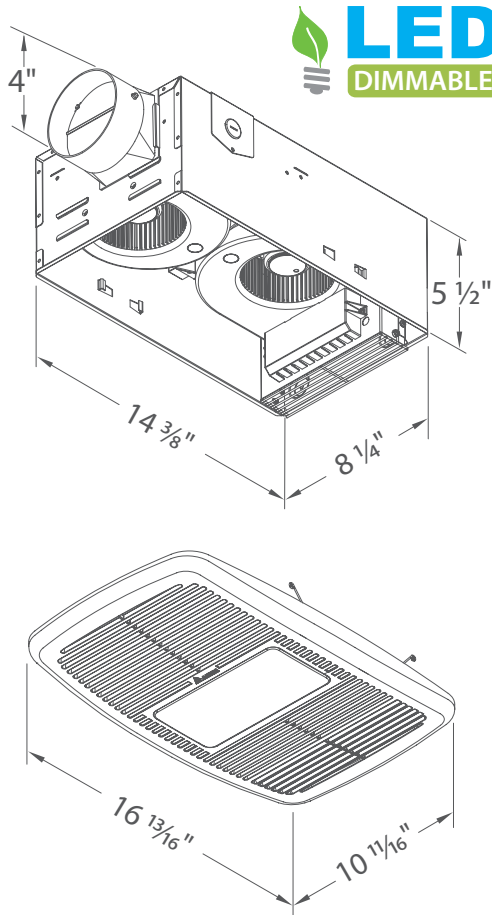

RAD110LED Fan/Dimmable LED Light/Heater

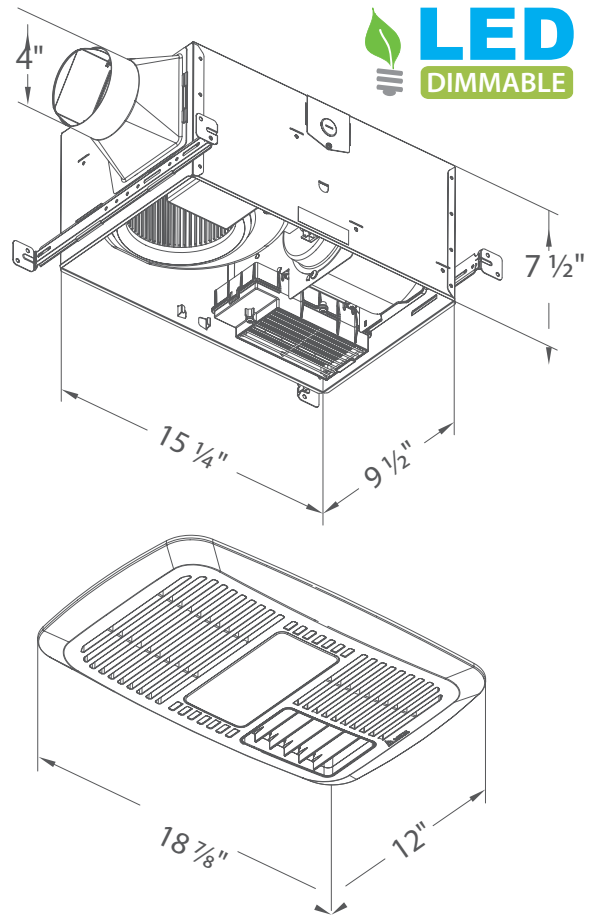

RAD80LED - 80 CFM
 Fan/Dimmable LED Light w/ Heater



Static Pressure (Inches w.g.)	0.1
Air Flow (CFM)	80
Sones	1.5
Power Consumption (Watts)	11.7
Energy Efficiency (CFM/Watts)	7.0
Current (Amps)	12
Power Rating (V/Hz)	120/60
Heating element (Watts)	1300
LED (Watts)	13
Total power (Watts)	1327

RAD110LED - 110 CFM
 Fan/Dimmable LED Light w/ Heater



Static Pressure (Inches w.g.)	0.1	0.25
Air Flow (CFM)	110	85
Sones	0.7	1.0
Power Consumption (Watts)	12.0	13.0
Energy Efficiency (CFM/Watts)	11.0	7.8
Current (Amps)	14	
Power Rating (V/Hz)	120/60	
Heating element (Watts)	1600	
LED Light (Watts/Lumens)	13/850	
Total power (Watts)	1650	



Professional (6" duct)

Large space solution.

Single speed 200 or 300 CFM. Quiet operation from 1 to 2 sones. For spaces 200-300 sq. ft. Perfect for large bathrooms, laundry rooms, conference rooms. UL approved for ceiling mount only.

Features:

- DC motor technology, energy saving up to 68.6%¹
- Galvanized steel body
- Detachable 6" diameter metal duct adapter
- Built-in backdraft damper
- LED indicator light green when power is on

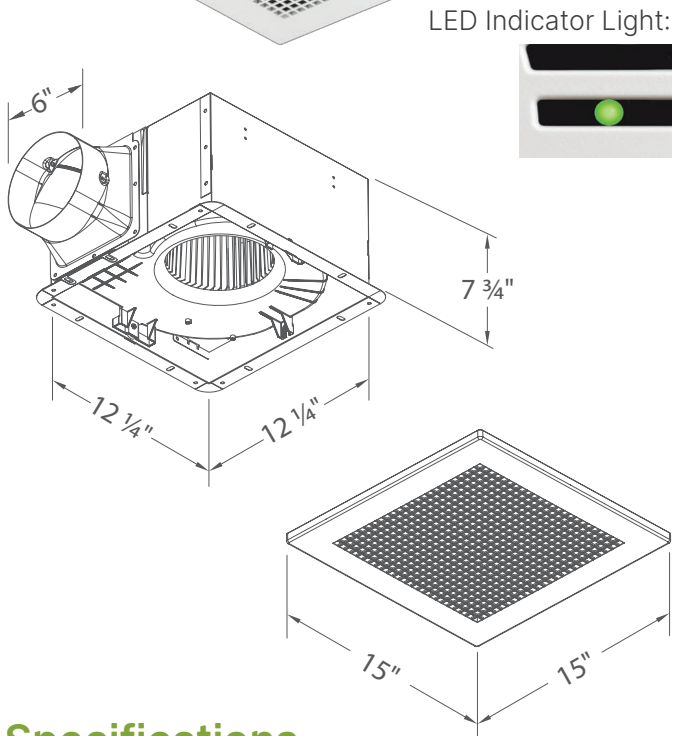

	Delta Breez	Market AC Motor
Energy Use (Watts)	17.5	57
Noise Level (Sones)	1.0	1.2
Annual Energy Cost per Fan (24/7) ²	\$18.40	\$58.59

1. Based upon Breez Pro200 vs. Market AC motor
 2. Calculations based upon U.S. average retail electricity. Actual results may vary

Specifications

Pro200*- 200 CFM Fan



Static Pressure (Inches w.g.)	0.1	0.25
Air Flow (CFM)	200	163
Sones	1.0	1.3
Power Consumption (Watts)	17.5	21.5
Energy Efficiency (CFM/Watts)	11.4	7.5
Current (Amps)	0.52 Max	
Power Rating (V/Hz)	120/60	

Pro300 - 300 CFM Fan



Static Pressure (Inches w.g.)	0.1	0.25
Air Flow (CFM)	300	268
Sones	2.0	2.5
Power Consumption (Watts)	41	43
Energy Efficiency (CFM/Watts)	7.3	6.2
Current (Amps)	0.72 Max	
Power Rating (V/Hz)	120/60	

* Product is ENERGY STAR Most Efficient 2022 distinction and ENERGY STAR qualified

SIG80-110 Fan Curve

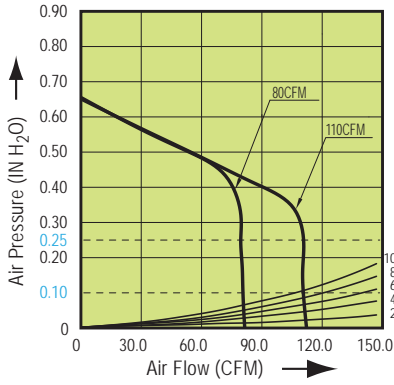

SIG80-110LED Fan Curve

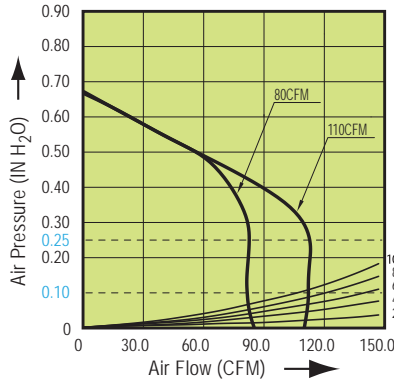

SIG80-110D Fan Curve

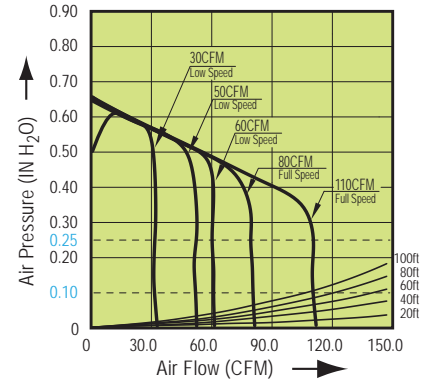

SIG80-110ELED Fan Curve

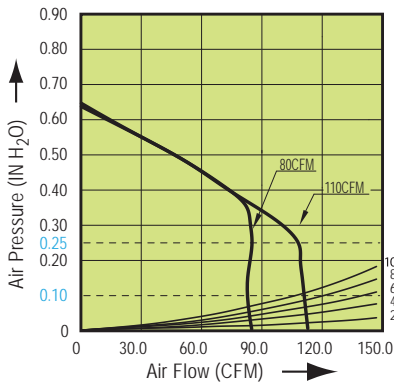

SIG80-110H Fan Curve

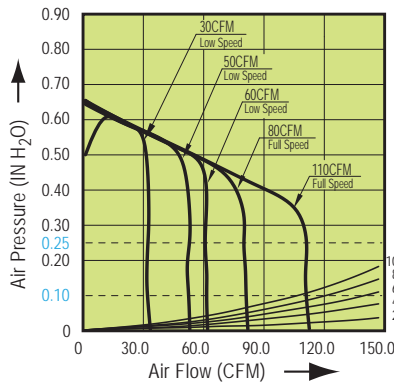

SIG80-110HLED Fan Curve

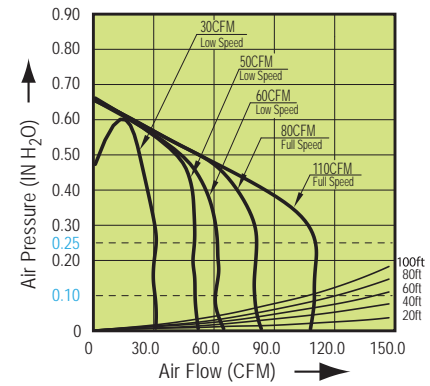

SIG80-110DLED Fan Curve

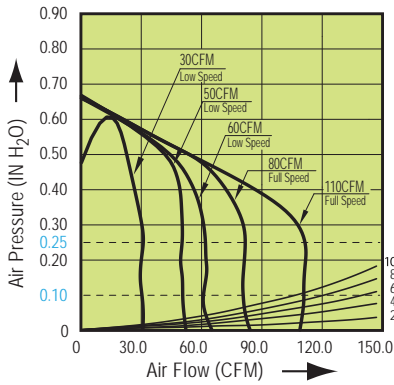

SIG80-110MH Fan Curve

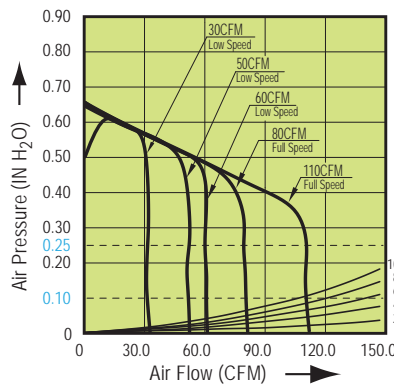

SIG80-110MHLED Fan Curve

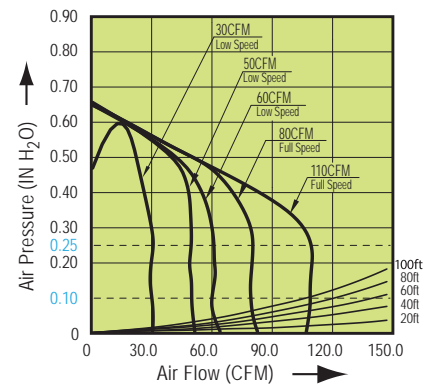

SIG80 Fan Curve

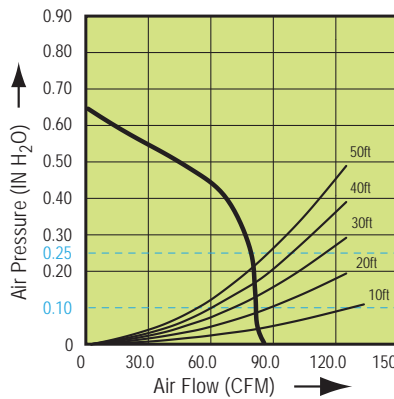

SIG80D Fan Curve

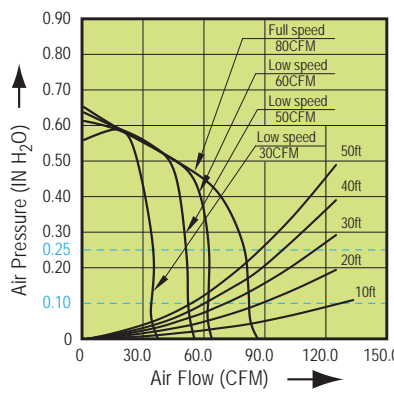

SIG110 Fan Curve

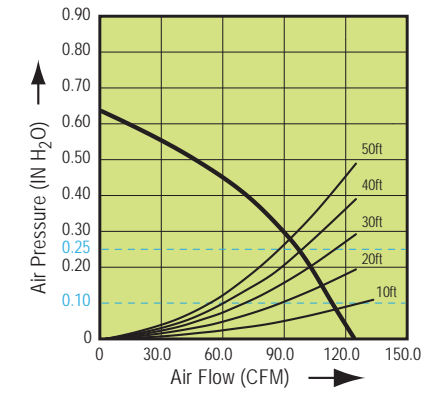

BreezSignature Fan Curves

VFB25ADBT Fan Curve

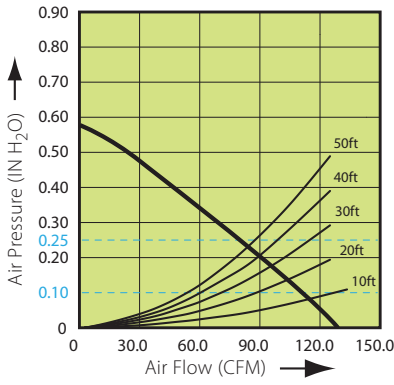

BreezElite Fan Curves

ELT80-110 Fan Curve

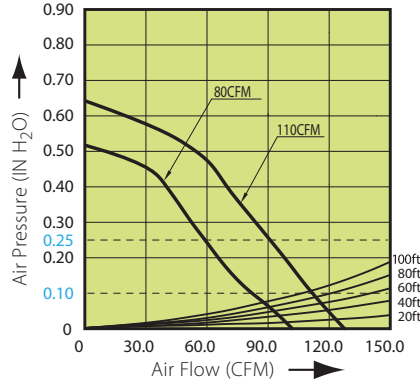

ELT80-110LED Fan Curve

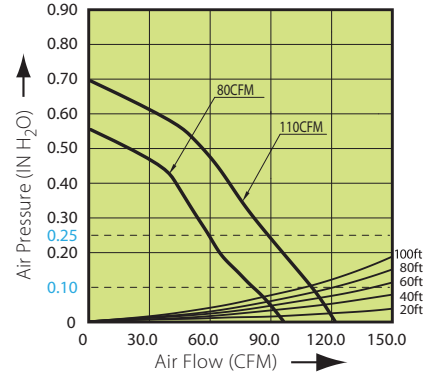

ELT80-110D / ELT80-110H ELT80-110MH Fan Curve

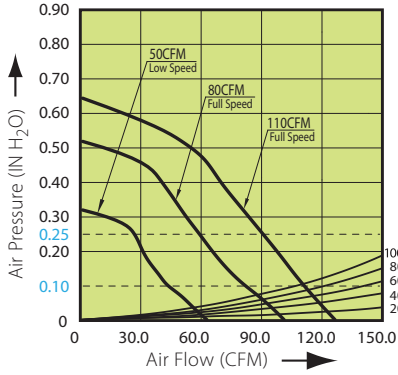

ELT80-110DLED / ELT80-110HLED ELT80-110MHLED Fan Curve

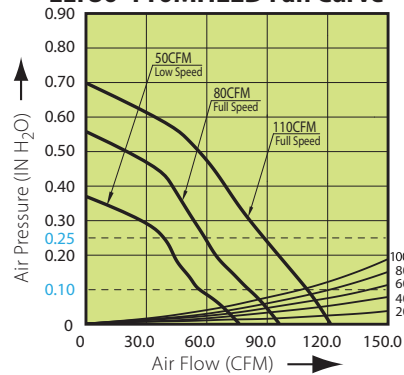

BreezSmart Fan Curves

SMT130 Fan Curve

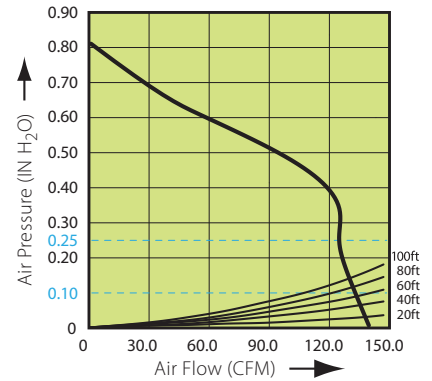

BreezSmart Fan Curves

SMT130H & SMT130M Fan Curve

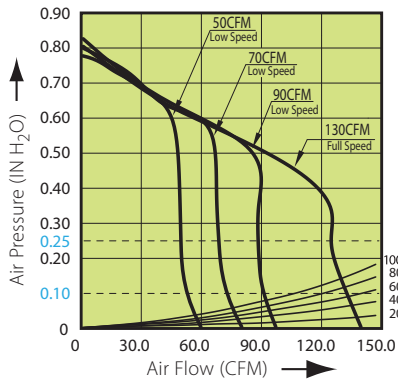

SMT150 Fan Curve

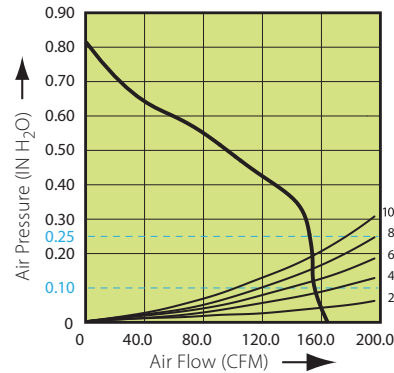

SMT150D Fan Curve

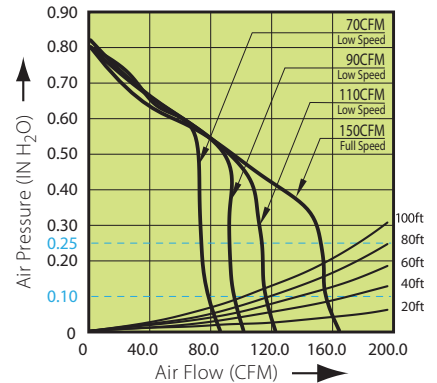

SMT150LED Fan Curve

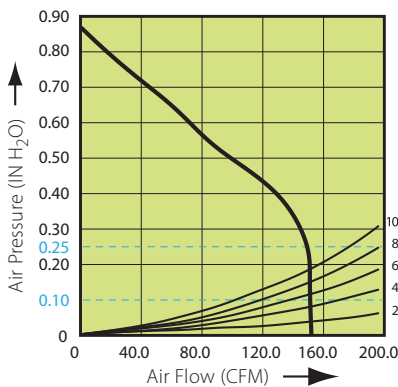

SMT150-200 Fan Curve

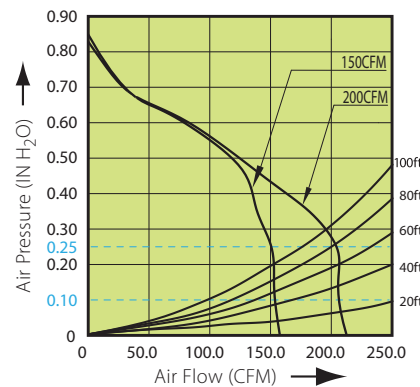

SMT150-200LED Fan Curve

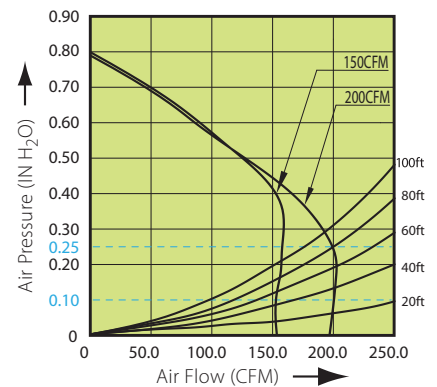

BreezGreenBuilder Fan Curves

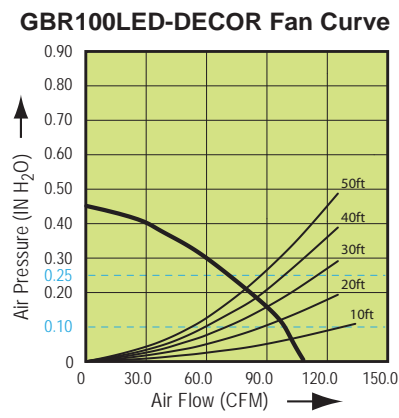
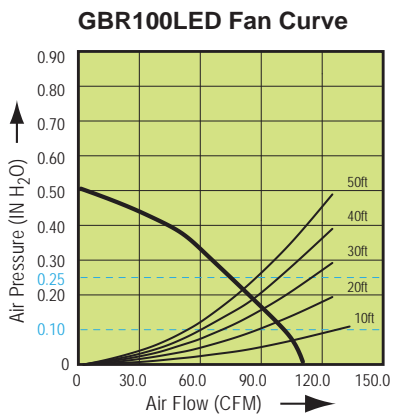
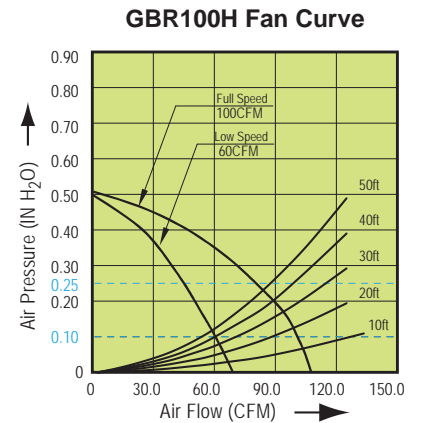
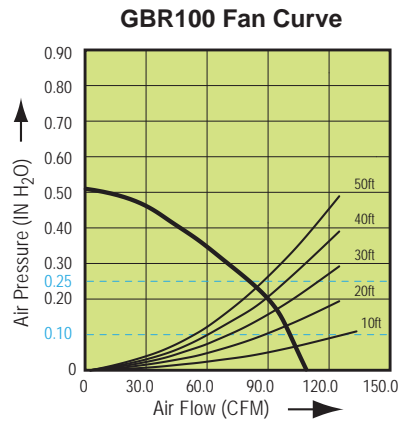
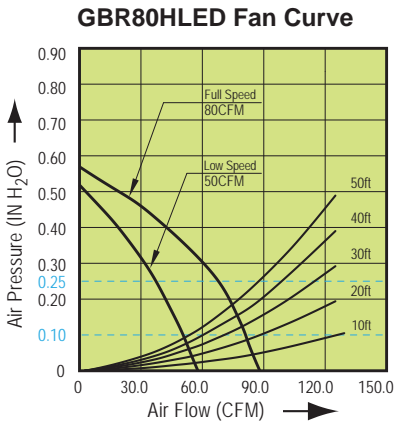
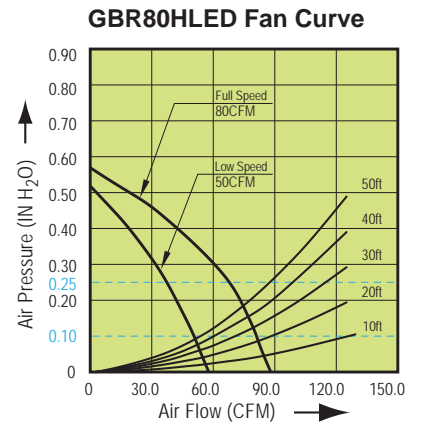
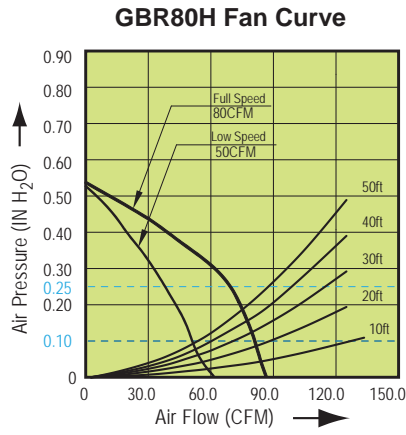
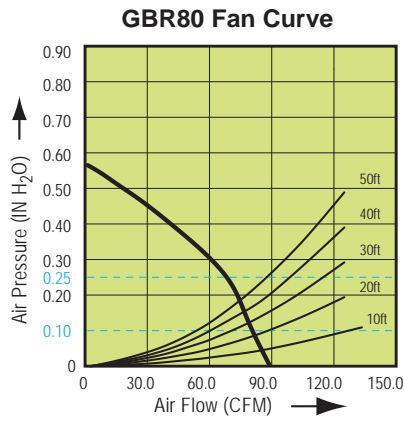

BreezSlim Fan Curves

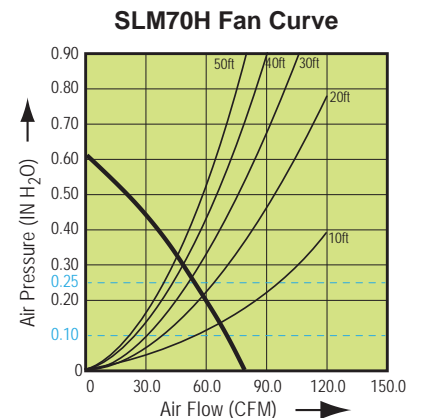
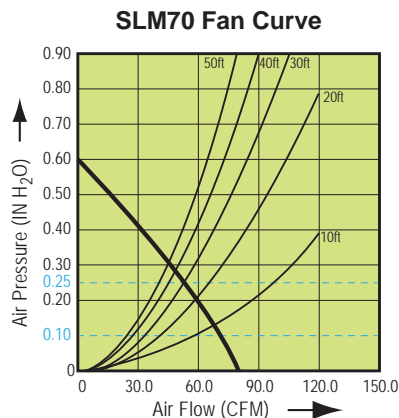
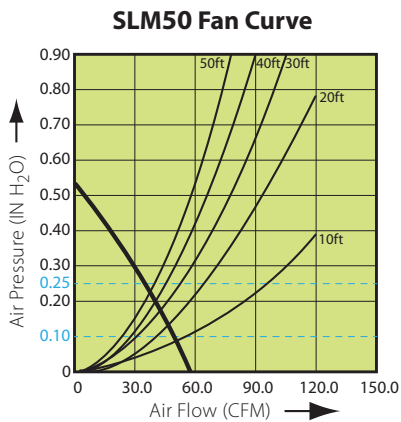

BreezSlim Fan Curves

SLM70D Fan Curve

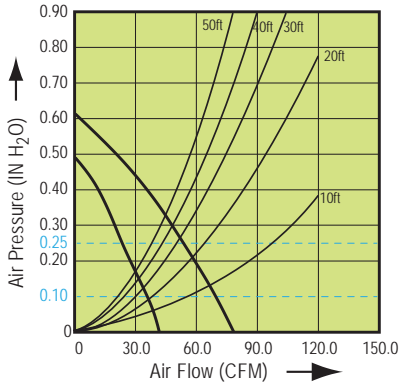

SLM70ELED Fan Curve

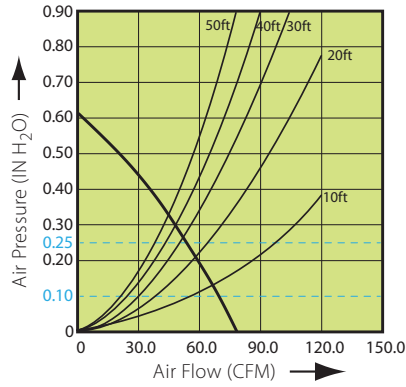

SLM80 Fan Curve

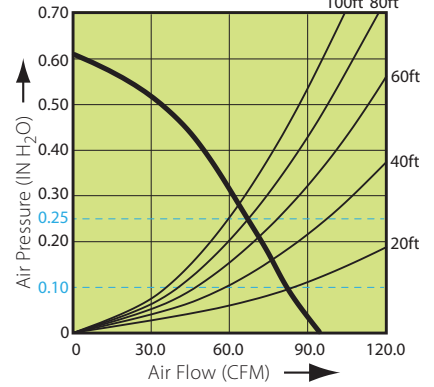

SLM80-110 & SLM80-110LED SLM80-110-C & SLM80-110LED-C

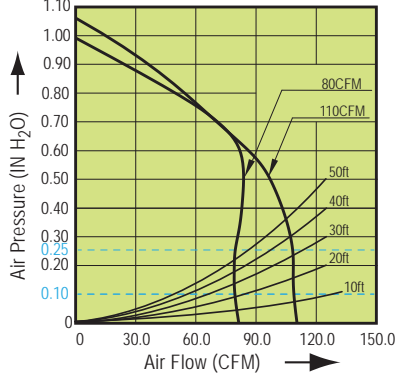

SLM80-110D & SLM80-110DLED SLM80-110D-C & SLM80-110DLED-C

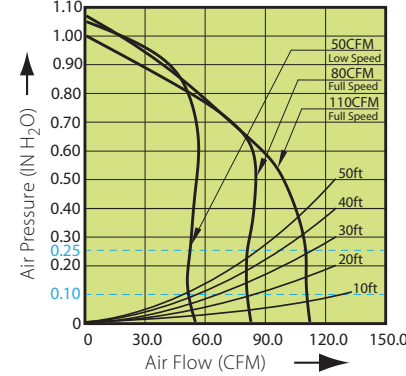

SLM100 Fan Curve

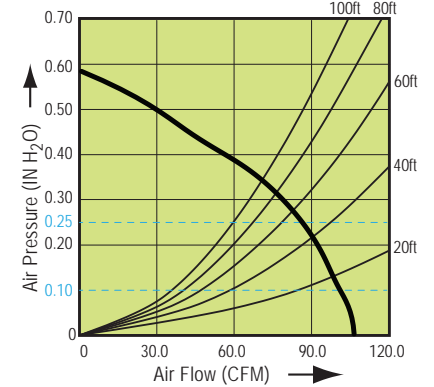

BreezIntegrity Fan Curves

ITG50 Fan Curve

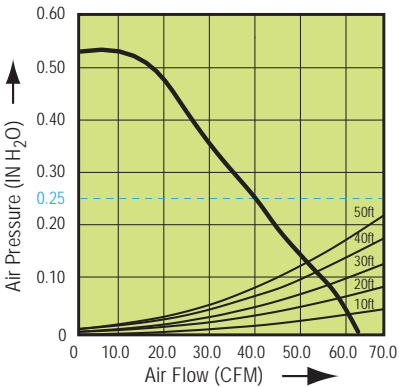

ITG50LED Fan Curve

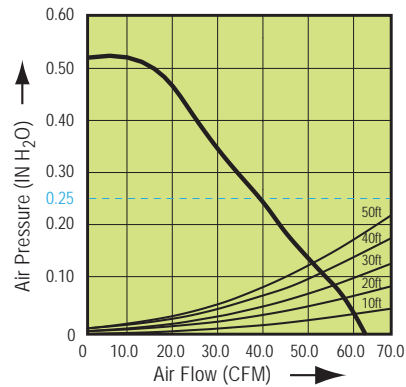

ITG70BT Fan Curve

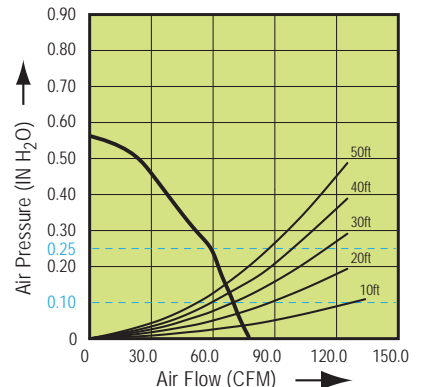

ITG80 Fan Curve

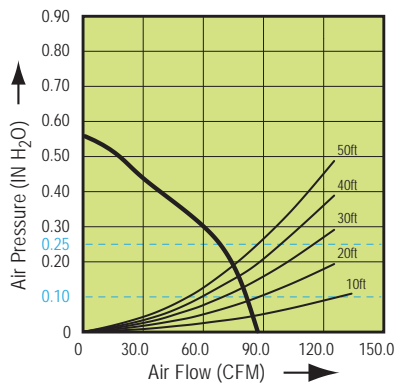

ITG80H Fan Curve

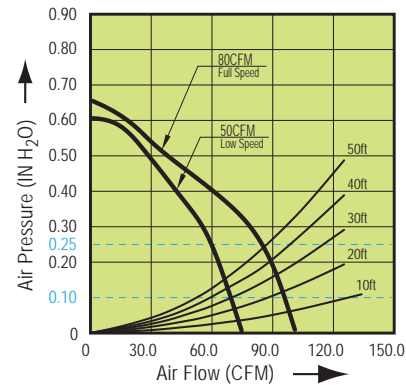

ITG80LED Fan Curve

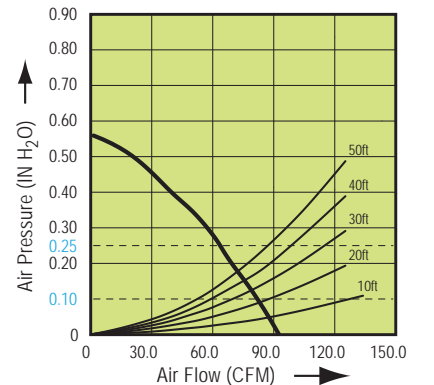

BreezIntegrity Fan Curves

ITG100 Fan Curve

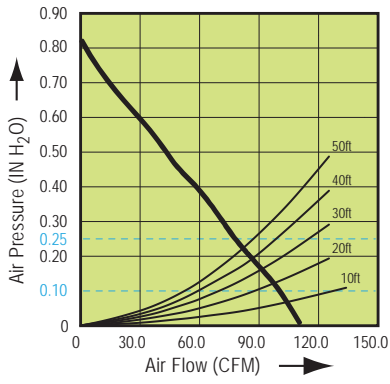

ITG100ELED Fan Curve

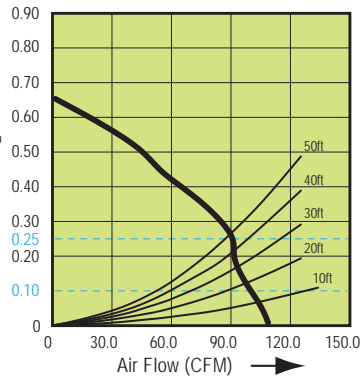

ITG100RLED Fan Curve

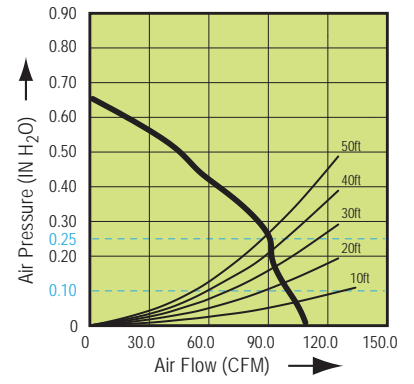

BreezRecessed Fan Curves

REC80LED Fan Curve

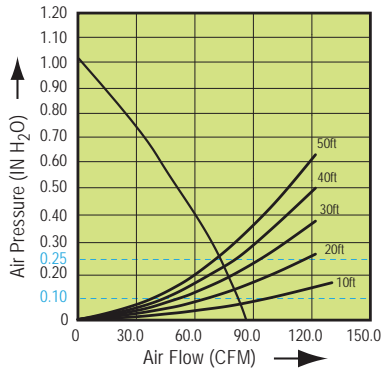

BreezPro Fan Curve

Pro200 Fan Curve

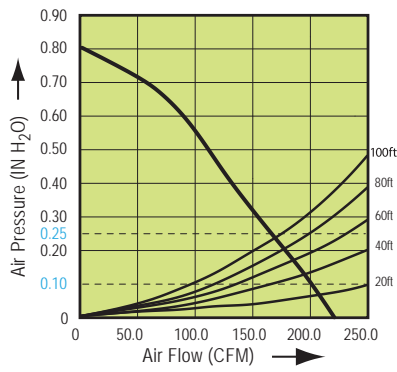

Pro300 Fan Curve

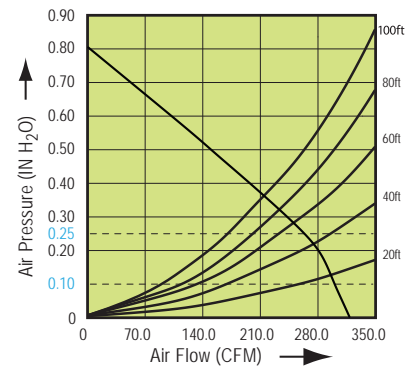

BreezRadiance Fan Curve

RAD80 Fan Curve

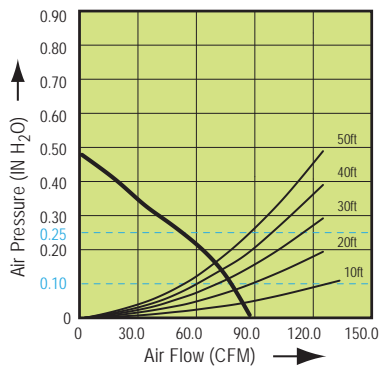

RAD80LED Fan Curve

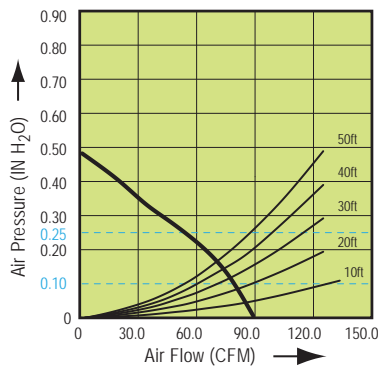

RAD110LED Fan Curve

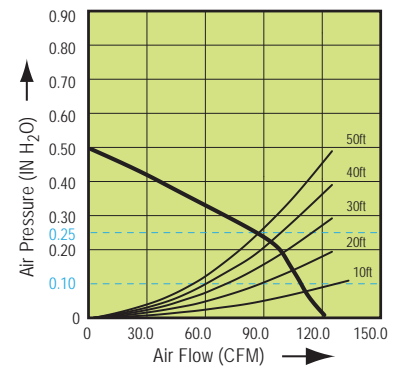

BreezFresh Fan Curves



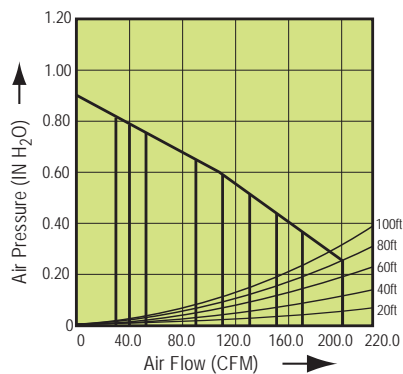

FRS200































PRODUCT SELECTION GUIDE: FIND THE MOST SUITABLE FAN

	Model #	Air Flow (CFM)	Duct Size	Description	
Signature	SIG80-110	80-110	6 inches	High Speed Options Fan	
	SIG80-110LED	80-110	6 inches	Fan/Dimmable LED Light/Night-Light	
	SIG80-110ELED	80-110	6 inches	Fan/Edge-lit Dimmable LED Light w/ adjustable color temperature	
	SIG80-110D	80-110	6 inches	Fan with Dual Speed	
	SIG80-110DLED	80-110	6 inches	Fan/Dimmable LED Light/Night-Light w/Dual Speed	
	SIG80-110H	80-110	6 inches	Fan with Humidity Sensor	
	SIG80-110HLED	80-110	6 inches	Fan/Dimmable LED Light/Night-Light w/ Humidity Sensor	
	SIG80-110MH	80-110	6 inches	Fan with Motion & Humidity Sensor	
	SIG80-110MHLED	80-110	6 inches	Fan/ Dimmable LED Light/Night-Light with Motion & Humidity Sensor	
	SIG80	80	4 inches	Single Speed	
	SIG80D	80	4 inches	Fan with Dual Speed	
	SIG110	110	4 inches	Single Speed	
	VFB25ADBT	110	4 inches	Fan with Bluetooth®	
Smart	SMT130	130	6 inches	Single Speed	
	SMT130M	130	6 inches	Fan with Motion Sensor	
	SMT130H	130	6 inches	Fan with Humidity Sensor	
	SMT150	150	6 inches	Single Speed	
	SMT150D	150	6 inches	Fan with Dual Speed	
	SMT150LED	150	6 inches	Fan/ Dimmable LED Light / Night-Light	
	SMT150-200	150-200	6 inches	High Speed Options Fan	
	SMT150-200LED	150-200	6 inches	Fan/Dimmable LED Light w/ adjustable color temperature	
Recessed	REC80LED	80	4 inches	Fan/Dimmable LED Light	
Elite	ELT80-110	80-110	6 inches	High Speed Options Fan	
	ELT80-110LED	80-110	6 inches	Fan/Dimmable LED Light	
	ELT80-110D	80-110	6 inches	Fan with Dual Speed	
	ELT80-110DLED	80-110	6 inches	Fan/Dimmable LED Light with Dual Speed	
	ELT80-110H	80-110	6 inches	Fan with Humidity Sensor	
	ELT80-110HLED	80-110	6 inches	Fan/Dimmable LED Light with Humidity Sensor	
	ELT80-110MH	80-110	6 inches	Fan with Motion and Humidity Sensor	
	ELT80-110MHLED	80-110	6 inches	Fan/Dimmable LED Light w/ Motion and Humidity Sensor	

LED Light
 Dimmable LED Light
 Adjustable motion sensor
 Adjustable humidity sensor
 Adjustable dual speed



Motor	Noise (Sones)	Energy Use (Watts)	Energy Efficiency (CFM/Watts)	Electric Bill ¹			Most Efficient 2022 www.energystar.gov		
								Intermittent	Continuous
DC	<0.3	6.2	15.4	\$6.52	Y	Y	Y	Y	
DC	<0.3	6.8 (Fan Only)	13.8	\$7.15	Y	Y	Y	Y	
DC	<0.3	7.5 (Fan Only)	11.7	\$7.89	Y	Y	Y	Y	
DC	<0.3	6.2	15.4	\$6.50	Y	Y	Y	Y	
DC	<0.3	6.8 (Fan Only)	13.8	\$7.20	Y	Y	Y	Y	
DC	<0.3	6.2	15.4	\$6.50	Y	Y	Y	Y	
DC	<0.3	6.8 (Fan Only)	13.8	\$7.20	Y	Y	Y	Y	
DC	<0.3	6.2	15.4	\$6.50	Y	Y	Y	Y	
DC	<0.3	6.8 (Fan Only)	13.8	\$7.20	Y	Y	Y	Y	
DC	<0.3	8.7	9.7	\$9.15	Y		Y	Y	
DC	<0.3	8.7	9.7	\$9.15	Y		Y	Y	
DC	<0.3	13.6	9.0	\$14.31	Y		Y	Y	
DC	1.0	14.2	7.7	\$14.94	Y		Y	Y	
DC	<0.3	11.6	11.2	\$12.10	Y	Y	Y	Y	
DC	<0.3	11.6	11.2	\$12.10	Y	Y	Y	Y	
DC	<0.3	11.6	11.2	\$12.10	Y	Y	Y	Y	
DC	<0.3	16.9	8.8	\$17.63	Y		Y	Y	
DC	<0.3	16.9	8.8	\$17.63	Y		Y	Y	
DC	0.5	17.6 (Fan Only)	8.5	\$18.51	Y		Y	Y	
DC	0.5	14.0	10.7	\$14.71	Y		Y	Y	
DC	0.5	15.0 (Fan Only)	10.0	\$15.77	Y		Y	Y	
DC	1.5	14.5 (Fan only)	6.1	\$15.25	Y		Y		
DC	0.5	7.0	11.4	\$7.36	Y	Y	Y	Y	
DC	0.5	7.0 (Fan Only)	11.4	\$7.36	Y	Y	Y	Y	
DC	0.5	7.0	11.4	\$7.36	Y	Y	Y	Y	
DC	0.5	7.0 (Fan Only)	11.4	\$7.36	Y	Y	Y	Y	
DC	0.5	7.0	11.4	\$7.36	Y	Y	Y	Y	
DC	0.5	7.0 (Fan Only)	11.4	\$7.36	Y	Y	Y	Y	
DC	0.5	7.0	11.4	\$7.36	Y	Y	Y	Y	
DC	0.5	7.0 (Fan Only)	11.4	\$7.36	Y	Y	Y	Y	

PRODUCT SELECTION GUIDE: FIND THE MOST SUITABLE

	Model #	Air Flow (CFM)	Duct Size	Description	
GreenBuilder	GBR80	80	4 inches	Single Speed	
	GBR80H	80	4 inches	Fan with Humidity Sensor	
	GBR80HLED	80	4 inches	Fan/Dimmable LED Light with Humidity Sensor	
	GBR80LED	80	4 inches	Fan/Dimmable LED Light	
	GBR100	100	4 inches	Single Speed	
	GBR100H	100	4 inches	Fan with Humidity Sensor	
	GBR100LED	100	4 inches	Fan/Dimmable LED Light	
	GBR100LED-DECOR	100	4 inches	Fan/Dimmable LED Light Decor	
Slim	SLM50	50	3 inches	Single Speed	
	SLM70	70	3 inches	Single Speed	
	SLM70ELED	70	3 inches	Fan with Edge-Lit Dimmable LED Light	
	SLM70H	70	3 inches	Fan with Humidity Sensor	
	SLM70D	70	3 inches	Fan with Dual Speed	
	SLM80	80	4 inches Oval	Single Speed	
	SLM100	100	4 inches Oval	Single Speed	
	SLM50-110-C	50-110	4 inches Oval	High Speed Options Fan	
	SLM50-110LED-C	50-110	4 inches Oval	Fan/Dimmable LED Light	
	SLM80-110H-C	80-110	4 inches Oval	Fan with Humidity Sensor	
	SLM80-110-C	80-110	4 inches Oval	High Speed Options Fan	
	SLM80-110D-C	80-110	4 inches Oval	Fan with Dual Speed	
	SLM80-110LED-C	80-110	4 inches Oval	Fan/Dimmable LED Light	
	SLM80-110DLED-C	80-110	4 inches Oval	Fan/Dimmable LED Light with Dual Speed	
	SLM80-110	80-110	4 inches Oval	High Speed Options Fan	
	SLM80-110D	80-110	4 inches Oval	Fan with Dual Speed	
	SLM80-110LED	80-110	4 inches Oval	Fan/Dimmable LED Light	
	SLM80-110DLED	80-110	4 inches Oval	Fan/Dimmable LED Light with Dual Speed	
Integrity	ITG50	50	4 inches	Single Speed	
	ITG50LED	50	4 inches	Fan/Dimmable LED Light	
	ITG70BT	70	4 inches	Fan with Bluetooth®	
	ITG80	80	4 inches	Single Speed	
	ITG80H	80	4 inches	Fan with humidity Sensor	
	ITG80LED	80	4 inches	Fan/Dimmable LED Light	
	ITG80RLED-ADJ	80	4 inches	Fan/Dimmable LED Light, Round, Adjustable Color Temperature	
	ITG100	100	4 inches	Single Speed	
	ITG100ELED	100	4 inches	Fan/Edge-lit Dimmable LED Light	
	ITG100RLED	100	4 inches	Fan/Edge-Lit Dimmable LED Light, Flat Round Panel	
Radiance	RAD80	80	4 inches	Fan with Heater	
	RAD80L	80	4 inches	Fan/Light Combo with heater	
	RAD80LED	80	4 inches	Fan/Dimmable LED Light with Heater	
	RAD110LED	110	4 inches	Fan/Dimmable LED Light with Heater	
Professional	Pro200	200	6 inches	Single Speed	
	Pro300	300	6 inches	Single Speed	

 LED Light
  Dimmable LED Light
  Adjustable motion sensor
  Adjustable humidity sensor
  Adjustable dual speed

FAN (cont.)

Motor	Noise (Sones)	Energy Use (Watts)	Energy Efficiency (CFM/Watts)	Electric Bill ¹			Most Efficient 2022 www.energystar.gov	ASHRAE 62.2 REQUIREMENTS	
								Intermittent	Continuous
DC	0.8	10.5	7.6	\$10.95	Y			Y	Y
DC	0.8	9.7	8.2	\$10.20	Y			Y	Y
DC	0.8	11.0 (Fan only)	7.2	\$11.57	Y			Y	Y
DC	0.8	11.0 (Fan only)	7.2	\$11.57	Y			Y	Y
DC	1.4	12.6	7.9	\$13.15	Y			Y	
DC	1.4	12.6	7.9	\$13.15	Y			Y	
DC	1.5	13.6 (Fan only)	7.3	\$14.31	Y			Y	
DC	1.5	13.0 (Fan only)	7.6	\$13.68	Y			Y	
DC	1.0	6.4	11.6	\$6.73	Y	Y			Y
DC	2.0	13.2	5.8	\$13.88	Y			Y	
DC	2.0	13.2 (Fan Only)	6.0	\$13.88	Y			Y	Y
DC	2.0	13.2	5.8	\$13.88	Y			Y	
DC	2.0	13.2	7.1	\$13.88	Y			Y	Y
DC	0.7	8.5	9.4	\$8.94	Y			Y	Y
DC	1.0	14.5	6.8	\$15.25	Y			Y	Y
DC	0.4	6.0	8.3	\$6.31	Y			Y	Y
DC	0.4	6.0 (Fan Only)	8.8	\$6.31	Y			Y	Y
DC	0.4	8.5	9.4	\$8.94	Y	Y		Y	Y
DC	0.4	8.5	9.4	\$8.94	Y			Y	Y
DC	0.4	8.5	9.4	\$8.94	Y			Y	Y
DC	0.4	9.0 (Fan Only)	8.8	\$9.47	Y			Y	Y
DC	0.4	9.0 (Fan Only)	8.8	\$9.47	Y			Y	Y
DC	0.4	8.5	9.4	\$8.94	Y			Y	Y
DC	0.4	8.5	9.4	\$8.94	Y			Y	Y
DC	0.4	9.0 (Fan Only)	8.8	\$9.47	Y			Y	Y
DC	0.4	9.0 (Fan Only)	8.8	\$9.47	Y			Y	Y
DC	0.7	5.0	12.5	\$5.26	Y	Y			Y
DC	0.7	5.0 (Fan Only)	12.5	\$5.26	Y	Y			Y
DC	1.0	8.4	10.6	\$8.83	Y	Y		Y	Y
DC	1.3	9.5	8.4	\$9.98	Y			Y	
DC	1.5	10.0	9.0	\$10.51	Y			Y	Y
DC	1.3	11.3 (Fan Only)	7.2	\$11.88	Y			Y	
DC	1.3	11.3 (Fan Only)	7.2	\$11.88	Y			Y	
DC	1.5	17.0	7.6	\$17.88	Y			Y	
DC	1.5	17.0 (Fan Only)	7.5	\$17.88	Y			Y	
DC	1.5	17.0 (Fan Only)	7.5	\$17.88	Y			Y	
DC	1.5	11.7	7.0	\$12.31				Y	
DC	1.3	10.5 (Fan Only)	7.0	\$11.04				Y	
DC	1.5	11.7 (Fan Only)	7.0	\$12.31				Y	
DC	0.7	12.0 (Fan Only)	11	\$12.62				Y	Y
DC	1.0	17.5	11.4	\$18.39	Y	Y		Y	Y
DC	2.0	41	7.3	\$43.09	Y			Y	

EQUIVALENT DUCT LENGTHS

This chart shows Equivalent Duct Lengths (EDL) for BreezSignature, BreezSlim, BreezGreenBuilder, BreezSmart, BreezRadiance, BreezProfessional, BreezIntegrity and BreezRecessed models by CFM (airflow) output for duct lengths from 40ft to 100ft.

	Breez Models	Description	Duct Size	40ft	60ft	80ft	100ft
Signature	SIG80-110 (80-110 CFM)	High Speed Options Fan	6 inches	110 CFM	110 CFM	110 CFM	110 CFM
	SIG80-110LED (80-110 CFM)	Fan/ Dimmable LED Light/Night-Light	6 inches	110 CFM	110 CFM	110 CFM	110 CFM
	SIG80-110ELED (80-110 CFM)	Fan/Edge-lit Dimmable LED Light w/ adjustable color temperature	6 inches	110 CFM	110 CFM	110 CFM	110 CFM
	SIG80-110D (80-110 CFM)	Dual Speed	6 inches	110 CFM	110 CFM	110 CFM	110 CFM
	SIG80-110DLED (80-110 CFM)	Fan/ Dimmable LED Light/Night-Light with Dual Speed Options Fan	6 inches	110 CFM	110 CFM	110 CFM	110 CFM
	SIG80-110H (80-110 CFM)	Fan with Humidity Sensor	6 inches	110 CFM	110 CFM	110 CFM	110 CFM
	SIG80-110HLED (80-110 CFM)	Fan/Dimmable LED Light/Night-Light w/ Humidity Sensor	6 inches	110 CFM	110 CFM	110 CFM	110 CFM
	SIG80-110MH (80-110 CFM)	Fan with Motion & Humidity Sensor	6 inches	110 CFM	110 CFM	110 CFM	110 CFM
	SIG80-110MHLED (80-110 CFM)	Fan/ Dimmable LED Light/Night-Light w/ Motion and Humidity Sensor	6 inches	110 CFM	110 CFM	110 CFM	110 CFM
	SIG80 (80 CFM)	Single Speed	4 inches	70 CFM	70 CFM	60 CFM	60 CFM
	SIG80D (80 CFM)	Dual Speed	4 inches	70 CFM	70 CFM	60 CFM	60 CFM
	SIG110 (110 CFM)	Single Speed	4 inches	90 CFM	90 CFM	80 CFM	80 CFM
	VFB25ADBT (110 CFM)	Fan with Bluetooth®	4 inches	90 CFM	80 CFM	70 CFM	70 CFM
Smart	SMT130 (130 CFM)	Single Speed	6 inches	130 CFM	130 CFM	120 CFM	120 CFM
	SMT130H (130 CFM)	Multi-Speed with Humidity Sensor	6 inches	130 CFM	130 CFM	120 CFM	120 CFM
	SMT130M (130 CFM)	Multi-Speed with Motion Sensor	6 inches	130 CFM	130 CFM	120 CFM	120 CFM
	SMT150 (150 CFM)	Single Speed	6 inches	150 CFM	150 CFM	140 CFM	140 CFM
	SMT150D (150 CFM)	Dual Speed	6 inches	150 CFM	150 CFM	140 CFM	140 CFM
	SMT150LED (150 CFM)	Fan/Dimmable LED Light / Night-Light	6 inches	150 CFM	150 CFM	150 CFM	150 CFM
	SMT150-200 (200 CFM)	Single Speed	6 inches	200 CFM	200 CFM	200 CFM	190 CFM
	SMT150-200LED (200 CFM)	Fan/Dimmable LED Light w/ adjustable color temperature	6 inches	200 CFM	200 CFM	200 CFM	190 CFM
Recessed	REC80LED (80 CFM)	Fan/Dimmable LED Light	4 inches	70 CFM	70 CFM	60 CFM	60 CFM
Elite	ELT80-110 (80-110 CFM)	High Speed Options Fan	6 inches	110 CFM	110 CFM	110 CFM	100 CFM
	ELT80-110LED (80-110 CFM)	Fan/Dimmable LED Light	6 inches	110 CFM	110 CFM	110 CFM	100 CFM
	ELT80-110D (80-110 CFM)	Dual Speed	6 inches	110 CFM	110 CFM	110 CFM	100 CFM
	ELT80-110DLED (80-110 CFM)	Fan/Dimmable LED Light with Dual Speed	6 inches	110 CFM	110 CFM	110 CFM	100 CFM
	ELT80-110H (80-110 CFM)	Fan with Humidity Sensor	6 inches	110 CFM	110 CFM	110 CFM	100 CFM
	ELT80-110HLED (80-110 CFM)	Fan/Dimmable LED Light w/ Humidity Sensor	6 inches	110 CFM	110 CFM	110 CFM	100 CFM
	ELT80-110MH (80-110 CFM)	Fan with Motion and Humidity Sensor	6 inches	110 CFM	110 CFM	110 CFM	100 CFM
	ELT80-110MHLED (80-110 CFM)	Fan/Dimmable LED Light w/ Motion and Humidity Sensor	6 inches	110 CFM	110 CFM	110 CFM	100 CFM
GreenBuilder	GBR80 (80 CFM)	Single Speed	4 inches	70 CFM	70 CFM	60 CFM	60 CFM
	GBR80H (80 CFM)	Fan with Humidity Sensor	4 inches	70 CFM	70 CFM	60 CFM	60 CFM
	GBR80HLED (80 CFM)	Fan/Dimmable LED Light w/ Humidity Sensor	4 inches	70 CFM	70 CFM	60 CFM	60 CFM
	GBR80LED (80 CFM)	Fan/Dimmable LED Light	4 inches	70 CFM	70 CFM	60 CFM	60 CFM
	GBR100 (100 CFM)	Single Speed	4 inches	80 CFM	70 CFM	70 CFM	60 CFM
	GBR100H (100 CFM)	Fan with Humidity Sensor	4 inches	80 CFM	70 CFM	70 CFM	60 CFM
	GBR100LED (100 CFM)	Fan/ Dimmable LED Light	4 inches	80 CFM	70 CFM	70 CFM	60 CFM
	GBR100LED-DECOR (100 CFM)	Fan/ Dimmable LED Light Decor	4 inches	80 CFM	70 CFM	60 CFM	60 CFM

EQUIVALENT DUCT LENGTHS (cont.)

	Breez Models	Description	Duct Size	40ft	60ft	80ft	100ft
Slim	SLM50 (50 CFM)	Single Speed	3 inches	40 CFM	30 CFM	30 CFM	30 CFM
	SLM70 (70 CFM)	Single Speed	3 inches	50 CFM	40 CFM	30 CFM	30 CFM
	SLM70H (70 CFM)	Fan with Humidity Sensor	3 inches	50 CFM	40 CFM	30 CFM	30 CFM
	SLM70D (70 CFM)	Dual Speed	3 inches	50 CFM	40 CFM	30 CFM	30 CFM
	SLM80 (80 CFM)	Single Speed	4 inches Oval	70 CFM	60 CFM	60 CFM	60 CFM
	SLM100 (100 CFM)	Single Speed	4 inches Oval	90 CFM	80 CFM	70 CFM	70 CFM
	SLM50-110-C (50-110 CFM)	High Speed Options Fan	4 inches Oval	110 CFM	100 CFM	100 CFM	90 CFM
	SLM50-110LED-C (50-110 CFM)	Fan/Dimmable LED Light	4 inches Oval	110 CFM	100 CFM	100 CFM	90 CFM
	SLM80-110H-C (80-110 CFM)	Fan with Humidity Sensor	4 inches Oval	110 CFM	100 CFM	100 CFM	90 CFM
	SLM80-110-C (80-110 CFM)	High Speed Options Fan	4 inches Oval	110 CFM	100 CFM	100 CFM	90 CFM
	SLM80-110D-C (80-110 CFM)	Dual Speed	4 inches Oval	110 CFM	100 CFM	100 CFM	90 CFM
	SLM80-110LED-C (80-110 CFM)	Fan/Dimmable LED Light	4 inches Oval	110 CFM	100 CFM	100 CFM	90 CFM
	SLM80-110DLED-C (80-110 CFM)	Fan/Dimmable LED Light w/ Dual Speed	4 inches Oval	110 CFM	100 CFM	100 CFM	90 CFM
	SLM80-110 (80-110 CFM)	High Speed Options Fan	4 inches Oval	110 CFM	100 CFM	100 CFM	90 CFM
	SLM80-110D (80-110 CFM)	Dual Speed	4 inches Oval	110 CFM	100 CFM	100 CFM	90 CFM
	SLM80-110LED (80-110 CFM)	Fan/Dimmable LED Light	4 inches Oval	110 CFM	100 CFM	100 CFM	90 CFM
	SLM80-110DLED (80-110 CFM)	Fan/Dimmable LED Light w/ Dual Speed	4 inches Oval	110 CFM	100 CFM	100 CFM	90 CFM
	Integrity	ITG50 (50 CFM)	Single Speed	4 inches	50 CFM	40 CFM	40 CFM
ITG50LED (50 CFM)		Fan/ Dimmable LED Light	4 inches	50 CFM	40 CFM	40 CFM	40 CFM
ITG70BT (70 CFM)		Fan with Bluetooth®	4 inches	60 CFM	60 CFM	50 CFM	50 CFM
ITG80 (80 CFM)		Single Speed	4 inches	70 CFM	70 CFM	60 CFM	60 CFM
ITG80H (80 CFM)		Fan with Humidity Sensor	4 inches	70 CFM	70 CFM	60 CFM	60 CFM
ITG80LED (80 CFM)		Fan/ Dimmable LED Light	4 inches	70 CFM	70 CFM	60 CFM	60 CFM
ITG80RLED-ADJ (80 CFM)		Fan/Dimmable LED Light, Round, Adjustable Color Temperature	4 inches	70 CFM	70 CFM	60 CFM	60 CFM
ITG100 (100 CFM)		Single Speed	4 inches	80 CFM	80 CFM	70 CFM	70 CFM
ITG100ELED (100 CFM)		Fan/Edge-lit Dimmable LED Light	4 inches	80 CFM	80 CFM	70 CFM	70 CFM
ITG100RLED (100 CFM)		Fan/LED Edge-Lit Dimmable, Flat Round Panel	4 inches	80 CFM	80 CFM	70 CFM	70 CFM
Radiance	RAD80 (80 CFM)	Fan with Heater	4 inches	70 CFM	60 CFM	60 CFM	50 CFM
	RAD80L (80 CFM)	Fan/Light Combo with heater	4 inches	70 CFM	60 CFM	60 CFM	50 CFM
	RAD80LED (80 CFM)	Fan/Dimmable LED Light with Heater	4 inches	70 CFM	60 CFM	60 CFM	50 CFM
	RAD110LED (110 CFM)	Fan/Dimmable LED Light with Heater	4 inches	90 CFM	80 CFM	70 CFM	70 CFM
Professional	Pro300 (300 CFM)	Single Speed	6 inches	270 CFM	250 CFM	230 CFM	210 CFM
Fresh	FRS200 (200 CFM)	High Speed Inline Fan	6 inches	200 CFM	200 CFM	200 CFM	190 CFM

The Right Fan for Any Ventilation Need

This quick guideline chart will help you match the correct bath fan size for your room size and type. HVI recommends the following intermittent ventilation rates for bathrooms:



Bathroom Size	Calculation Formula	Ventilation Rate Required
Less than 100 sq ft More than 100 sq ft	1 CFM per sq ft of floor area Add the CFM requirement for each fixture	A minimum of 50 CFM Toilet 50 CFM Shower 50 CFM Bathtub 50 CFM Jetted Tub 100 CFM

Reference: <https://www.hvi.org/resources/publications/bathroom-ventilation/>



Delta Breez is powerful, durable, quiet and efficient

Backed by nearly 30 years of innovation and consistent quality, the DC brushless motor technology inside every Delta Breez product is why Breez ventilation fans is the new industry standard for energy efficient performance. All Delta Breez fans are:

- + Rigorously tested to reduce noise
- + Equipped with soft start and lock protection functions
- + Engineered to run continuously for a minimum of 70,000 hours

Energy Saving Bathroom Solution

The introduction of the Breez ventilation fan ushered in a new era in green construction for bathroom ventilation. The Breez ventilation fan delivers an aesthetically pleasing ventilation solution that consumes less power with advanced functionality, operating more quietly than most AC motor products on the market.

Features and benefits that blow you away

- + Quiet – measured at the lowest noise level (less than 0.3 sones) a bath fan can be tested for HVI certification.
- + Low Energy Costs – consumes up to 85% less energy than other leading fans, with as little as 4 Watts versus 45 Watts
- + Long-lasting features -- precision engineered Delta brushless DC fan motors for superior performance and reliability. Made to outlast AC fan motors by as much as 70%, reducing the frequency of motor replacement
- + Easy Installation – Breez retrofit models can fit into most existing bath ceiling cut-outs
- + Certification – exceeds ENERGY STAR requirements by up to 367%¹. UL and cUL listed for tub/shower enclosure when used with GFCI branch circuit wiring

1 Based upon ENERGY STAR V4.0 Criteria for residential ventilating fans

2 Calculations based upon U.S. average retail electricity. Actual results may vary

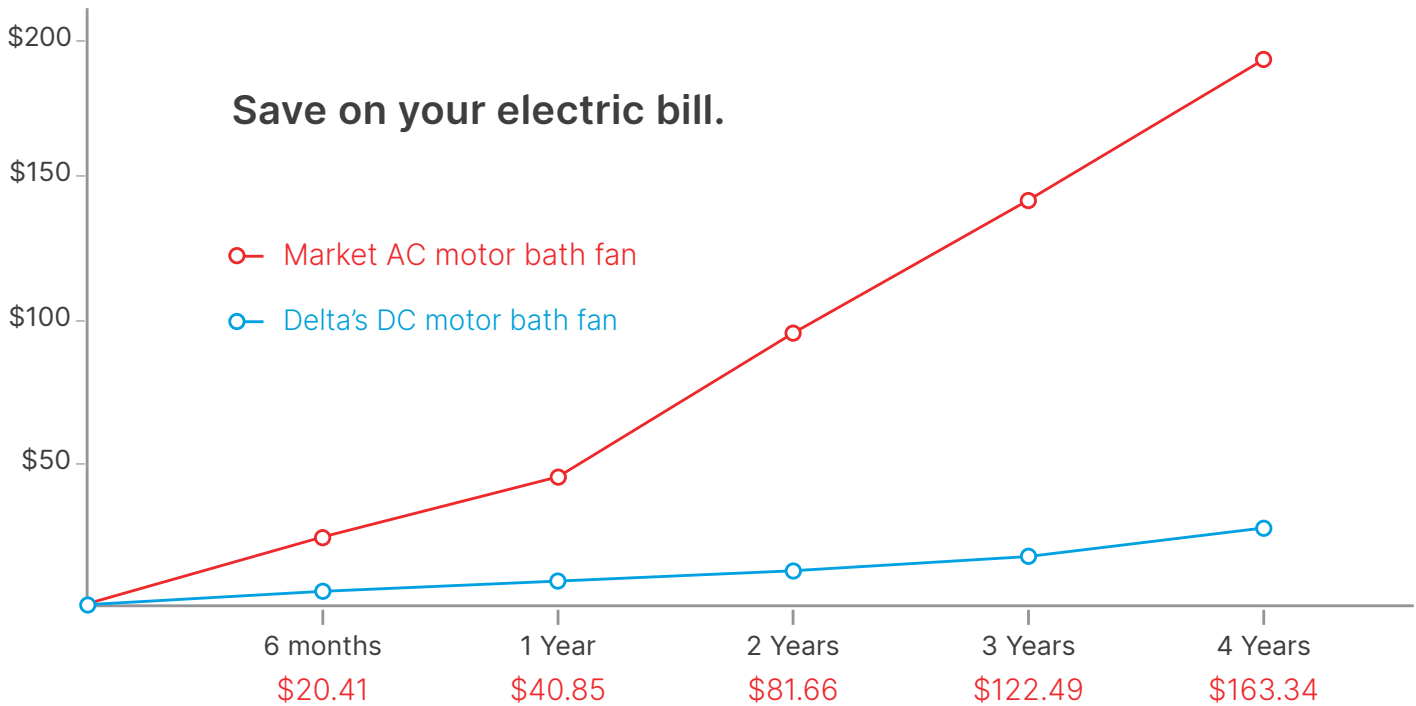

FAQs

Who is the Delta Group?

The Delta Group is the world's largest manufacturer of brushless DC motor fans and a leading provider of switching power supplies – a \$9 billion global company with 39 manufacturing facilities, 70 R&D labs and 169 sales offices worldwide and U.S. headquarters in Fremont, CA. Our company mission is “To provide innovative, clean and energy-efficient solutions for a better tomorrow” supported by a product portfolio that features a range of energy efficiency solutions including ventilation fans, small wind energy systems, solar panels, LED lighting, EV chargers, Industrial Automation products and Display Solution products. Delta's operations are ISO-9001, ISO-14001, ISO-14064, OHSAS-18001 and TS-16949 certified. Delta brushless DC motor fans are used in applications where precision is paramount. This includes consumer electronics products such as laptops, desktops, tablets and gaming systems from leading manufacturers.

Please visit our global website www.deltaww.com for a more comprehensive look at Delta operations, products and capabilities.

Why is a brushless DC motor better than an AC motor? Does it require any special installation or wiring?

Delta's brushless DC motor exhaust fans are engineered to run 70% longer and consume 74% less power than AC motor exhaust fans, which reduces replacement costs and saves on utility bills. No mechanical brushing means quieter operation and less wear on motor components. Delta Breez fans have been tested to run continuously for a minimum of 70,000 hours.

No special wiring is needed. There is a transformer built into the fan that automatically switches the power supply from AC to DC.

Delta's DC Breez ventilation fans are installed just like any AC motor fans.

What is the “Soft Start” Function?

In the first 10 seconds the fan is powered on, the motor will softly and quickly ramp up to full speed. This is unlike an AC Motor, which simply jump-starts the fan. This quiet ‘soft start’ process helps reduce the wear on motor bearings to prolong fan life.

What is the “Lock Protection” Function?

This unique function allows all Delta Breez ventilation fans to automatically power off when the impeller is abnormally locked. For example: when buildup of dirt and dust accumulates in the fan, the fan will attempt to restart itself in 5-10 seconds. If the impeller is still blocked, the fan will remain off -- this helps avoid the issue of over-heating or motor burnout, reducing the risk of fire.

What is the purpose of the LED indicator light underneath the fan grille?

The light shows the user that the fan is in operation. If the fan has different functions available (i.e. humidity sensing, low speed, motion sensing), the light will change color indicating what mode the fan is in. The light will blink if the impeller gets obstructed, telling the user that the fan is not operating properly.

What are CFM and sones?

CFM and sones are how bath fans are generally compared. CFM (cubic feet per minute) measures the speed of ‘air flow’ – the amount of air extracted per minute when the fan is running. The amount of CFM needed is generally related to the size of the area ventilated. Please see the sizing guidelines.

Sone level represents how loud the fan is to the human ear. Doubling the sone value means double the noise. The average 80 CFM bath fan runs at 0.8~2.5 sones. Delta Breez 80 CFM fans run as low as <0.3 sones. At less than 0.3 sones, the fan is virtually silent. This is the lowest noise rating of any exhaust fan on the market. For reference, 1.0 sone is about as loud as a new computer or refrigerator. For more information, visit

<https://www.hvi.org/resources/videos/>

How do I determine which bath fan I need – features and size?

Bathroom Ventilation

The following are Home Ventilating Institute (HVI) guidelines for ventilating both large and smaller bathrooms using intermittent or continuous ventilation.

Small rooms:

For bathrooms up to 100 square feet in area, HVI recommends that an exhaust fan provide 1 CFM per square foot (approximately eight air changes per hour) to properly ventilate the bathroom.

Example:

- Bathroom is 8' x 5' (with 8' ceilings)
Multiply 8 x 5 = 40 sq. ft.
- Bathroom area is 40 sq. ft.
- At 1 CFM per square foot the minimum recommendation is a fan rated at 40 CFM

Larger rooms:

For bathrooms above 100 square feet in area, HVI recommends a ventilation rate based on the number and type of fixtures present, according to the following table:

Toilet	50 CFM
Shower	50 CFM
Bath Tub	50 CFM
Jetted Tub	100 CFM

Note: Enclosed toilet rooms must have an operable window or a fan for ventilation

Example:

The bathroom is 20' x 12'. There is a tub (without jets), a shower enclosure and an enclosed toilet.

Each fixture requires 50 CFM:

Tub	50 CFM
Shower	50 CFM
Toilet	50 CFM
Total	150 CFM

Data source: <https://www.hvi.org/resources/publications/bathroom-ventilation/>
Or you can visit <https://www.hvi.org/resources/videos/>

How does the "Humidity Sensor" function operate?

The fan runs at full speed until the user-adjustable humidity set-point is achieved, then automatically switches to the user set low speed for continuous run or off. The amber or blue color of the LED indicator light underneath the grille shows the humidity sensing mode or continuous low speed mode. Please consult the Installation & Operating Instruction manual for your particular fan model for more specific information.

How does the "Motion Sensor" function operate?

When motion is detected, the fan comes on at full speed. When the user leaves the room, the fan will continue running at full speed until user-preset delay time has passed. Then, the fan will automatically drop down to the pre-set low speed for continuous run or off. The green or amber color of LED indicator

light underneath the grille indicates continuous low speed or full speed mode. Please consult the Installation and Operating Instruction manual for your particular fan model for more specific information.

Can I keep the housing of my old fan (non Delta fan) and just replace the fan motor with Breez?

No. For proper performance, it is recommended that Delta Breez fan motors be used only with Delta Breez fan housing.

Can I use a timer with the Delta Breez fan?

Many Delta Breez models have built-in adjustable delay timers, so no external timer is needed. External timers can be used in conjunction with single-speed models only. Because Breez fans run on much lower wattage than other market ventilation fans, please contact Delta Breez customer service for a list of single-speed models and consult with a licensed electrician for compatibility.

Do you sell switches or timers?

No. Delta does not manufacture switches or timers, but these components are readily available in most major home improvement retailers or through your local contractor or supplier.

Can the Delta Breez Fan/Light be installed with insulation around it?

Yes, all Delta Breez fans are UL approved. Here is UL's testing protocol:

For Fan/lights, UL requires 8.5 inches of insulation on all sides (including top) of the product. Insulation shall be of the loose fill type and should have a thermal resistance per inch between 3.75-3.85 R (declared by the manufacturer) when conditioned to a density of 32.04 - 40.05 kg/m³. This scenario is equivalent to an approximate R value of R32. R40 is the max for Canadian installations.

For a fan only, there is no insulation limitation for fan without lighting except in Canada where the max value is R40.

Can Delta fans be controlled by a voltage switch (RPM control)?

No.

Is LED light replaceable or are replacements available?

Delta Electronics designs our own LED modules. This is a customized LED module that cannot be replaced with an off-the-shelf, screw-in LED bulb from another manufacturer. The LED modules are designed to last a minimum of 30,000 hours, so the necessity for future replacement is unlikely. Delta Electronics has a 3-year limited warranty on every Delta designed LED module. If the LED module needs replacement outside of the warranty period, a replacement LED module can be purchased through our distributor partners or from Delta Customer Sales Support.

What are the built-in control functions and how do they work?

Motion Sensing

Green and amber LED indicator lights will show continuous low speed and full speed modes. The fan will run continuously at a user-preset lower level of CFM. When motion is detected, the fan will automatically change to full speed. When the user leaves the room, the fan will remain running at full speed until user-preset delay time has passed. The delay timer has adjustable preset positions of 0, 0.5, 5, 15, 30, 45 and 60 minutes. The fan will automatically drop down to a low speed after the pre-set time has elapsed.

Humidity Sensing

Blue and amber LED indicator lights show humidity control and full speed modes. The fan will operate in full speed mode or humidity control mode through the manual on and off switch. The adjustable humidity set points are from 50% to 90%. When in humidity control mode and the humidity is above the user-adjustable set-point, the fan will run at full speed. When the humidity is below the set-point, the fan runs continuously at a user-preset lower level of CFM.

Can Delta fans be installed in a slanted ceiling?

No, installation of any Delta fan in a slanted ceiling is not recommended.

Is it OK to exhaust into the attic?

No, the American Society of Heating, Refrigerating and Air-Conditioning Engineers (ASHRAE) recommends exhausting only to the exterior of the home.

Can Delta fans be installed in a side wall?

Yes, all Delta BreezSlim models, BreezGreenBuilder fan

only/fan with humidity sensor models, and BreezIntegrity fan only/fan with humidity sensor models are UL listed for both ceiling and wall-mount installation.

Can I install the Exhaust Fan / Light in the shower or tub enclosure?

Yes, with Delta Breez Ventilation Fans, except BreezRadiance due to the heating element, are UL listed for use over the bathtub or shower when installed in a GFCI protected branch circuit.

How long do LEDs last?

LEDs have a rated life of up to 30,000 hours. Used for 12 hours a day, a 30,000 bulb will last more than 6 years.

Used 8 hours a day, it will last more than 10 years!

Are Delta Breez fans ENERGY STAR qualified?

Yes, Delta Breez fans are ENERGY STAR qualified. The only exception is BreezRadiance series with heater element for warmth and comfort.

Are Delta Breez fans ASHRAE 62.2-2010 compliant?

Yes, all Delta Breez fans are 62.2-2010 compliant for intermittent running. Most of the Delta Breez fan models are compliant for continuous running. Please see www.deltabreez.com, Learning Center for a complete listing.

Are Delta Breez fans UL listed and HVI certified?

Yes, all Delta Breez fans are UL listed and are HVI certified.

Do Delta Breez fans meet Title 24 requirements?

Yes, all Delta Breez fans meet current Title 24 requirements.

What is the Delta Breez Ventilation Fan Warranty?

All Delta Breez Ventilation Fans have a 3-year limited warranty.

How do I reach technical support and customer service?

Technical support: (888) 979-9889

Email: BreezTechSupport@deltaww.com

Customer sales support: (877) 685-4384

Email: BreezSalesSupport@deltaww.com

Fax: (510) 226-5098

STAY FRESH & DRY

QUIETLY EFFICIENT IN EVERY WAY



In 2022, Delta Breez ushered in a new era for the water damage restoration and janitorial/sanitation industries by launching the **AMR1200**, the first centrifugal air mover to use a DC motor. This technology allows our air movers to be more energy-efficient, quieter, and lighter than ever before. Our patented dual intake air flow technology along with digital control offers our customers better performance and convenience while saving electric usage and expense.

Efficient air flow solution. 1200 CFMs of air delivery while only using 97W and 1.4Amps to cool or dry any space up to 32 ft. Quiet operation at 55 dB-A and lightweight at 12.4 lbs.

Ultra Quiet Energy-Efficient Brushless DC Motor Technology

- Built-in Power Outlet for Daisy Chainable



- Stacked 4 Units for Storage



- Simple Operation



AMR1200

Features:

- High efficiency brushless DC motor, offers energy savings of up to 70% compared with similar products with AC motors.
- Delivers 1,200CFM of airflow while using only 97W and 1.4Amps.
- Super low noise operation of 55 dB-A at high speed, up to 12 dB-A lower than similar models.
- Digital control panel with LED display controls 3 speeds, timer function, and continuous time counter, up to 99Hrs.
- Patented dual blade design creates an airflow stream up to 32ft.
- Low 1.4Amp draw allows for up to 8 units to be daisy-chained with 2 receptacles (15A circuit breaker).
- Stackable up to 4 units high for easy storage.
- Lightweight 12.4lb design, arc-shaped handle, and balanced center of gravity allows for easy carrying.
- 3-angle drying positions (0°, 45°, 90°) can be used.

Applications

- Drying floors and carpet, ceilings and walls paint, indoor air circulation, bathroom, garage cooling, basements, work space, exhibition hall, supermarket, and theater.

Specifications

AMR1200

Net Weight (Lb.)	12.4		
Nominal Voltage (VAC / Hz)	120/60		
Input Power (Watts)	30	56	97
Current (Amp.)	0.5	0.9	1.4
Speed (RPM)	642	804	966
Air flow (CFM)	800	1000	1200
Noise (dB-A)	45	51	55

* Noise is measured in semi-anechoic chamber in free air, with three microphone at back and two side in 3.28 feet for average.

* The test result of the airflow in free air is central value with tolerance range of ±10%.

* All readings are typical values at rated voltage.

* Specifications are subject to change without notice.



Dimension

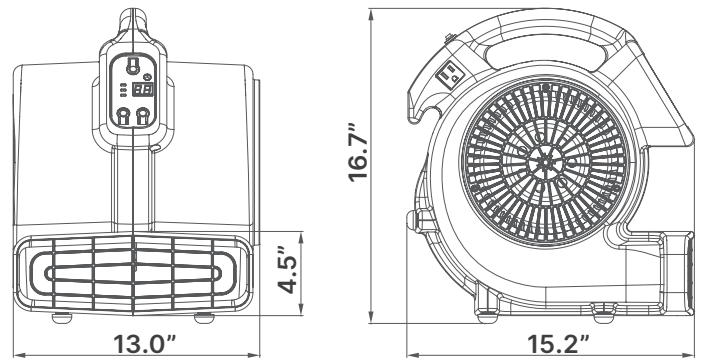

Unit: Inch

Three Angle Drying Positions



1. Dry the carpet and the floor
2. Dry the painted walls, indoor air circulation
3. Dry the ceiling paint, indoor air circulation



Air Quality Solutions Products: Power saving. Quietness. New life.

Delta offers ceiling fans that meet the highest efficiency standards, recognized as ENERGY STAR® Most Efficient, with smooth start-up, quiet operation, low vibration and uniform multi speed airflow for a great user experience. The excellent power electronic control and airflow design make the ceiling fan runs smoothly and quietly. The simple and chic exterior design is eye-catching.

Breez RioVista (8-blade) or Pleasanton (5-blade) offer 72 inch or 60 inch ceiling fans with dimmable LED light and an easy pairing remote Control. The ceiling fans are available in two color options, matt black or matt white.

Features:

- Energy saving, full product line meet ENERGY STAR Most Efficient 2022
- Increased energy efficiency with powerful and quiet DC motor
- Energy efficient DC motor with 6 speeds and reverse function
- Includes Fan/Light Handheld Remote Control
- Easy remote pairing
- 20W dimmable LED light included

- Wet rated, for indoor/outdoor use
- Smooth start-up
- Threaded downrod $\frac{3}{4}$ " Dia x 6" L, tighter stability

Applications

Fan is rated for dry, damp, and wet locations. These ceiling fans can be installed in many different spaces, such as the living room, dining room, bedrooms, and wet locations such as a patio or lanai. Light commercial application include restaurants, offices, hotels, and resorts.



RioVista 72" or 60" 8-blade with dimmable LED light and remote control. Matt black or matt white finish.

Pleasanton 72" or 60" 5-blade with dimmable LED light and remote control. Matt black or matt white finish.



remote control included



Sizes and Dimensions

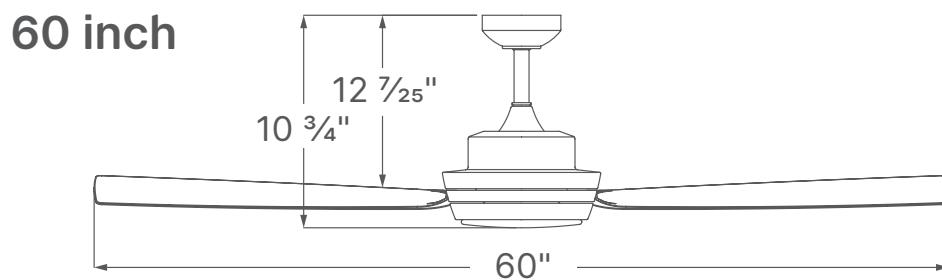
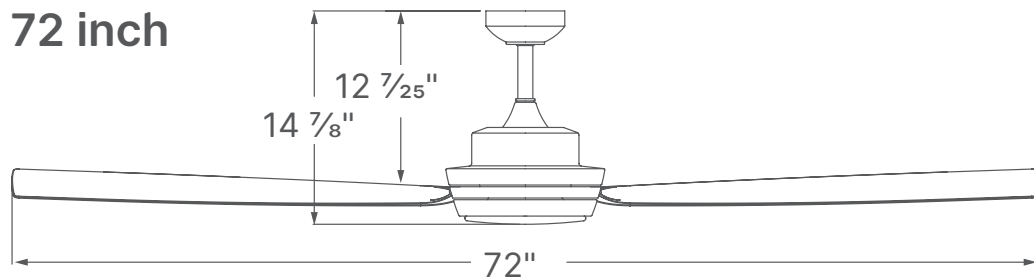



Choose a ceiling fan size



Fan Diameter over 60"-72"
Recommended Room Size: over 18'x20'



Fan Diameter over 52"-60"
Recommended Room Size: up to 18'x20'

Comfort and Energy Saving

In Summer

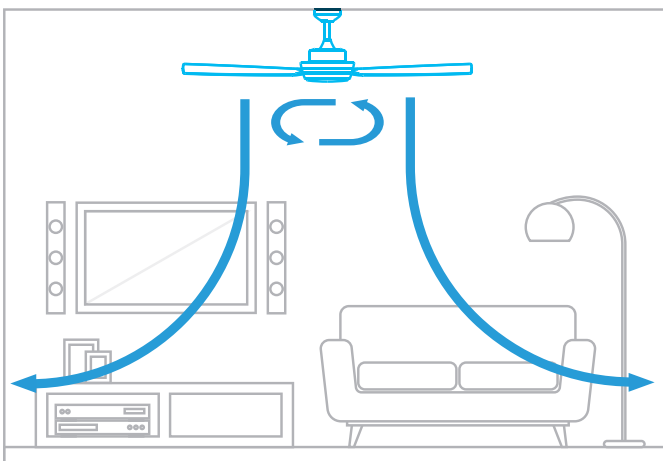

- In summer, the fan should be set to blow downward
- If using air conditioning to cool the home, a ceiling fan will allow to raise the thermostat setting about 4°F with no reduction in comfort. (air conditioner savings 4~8%)
- During hot weather, ceiling fans may allow you to avoid using your air conditioner altogether

In Winter

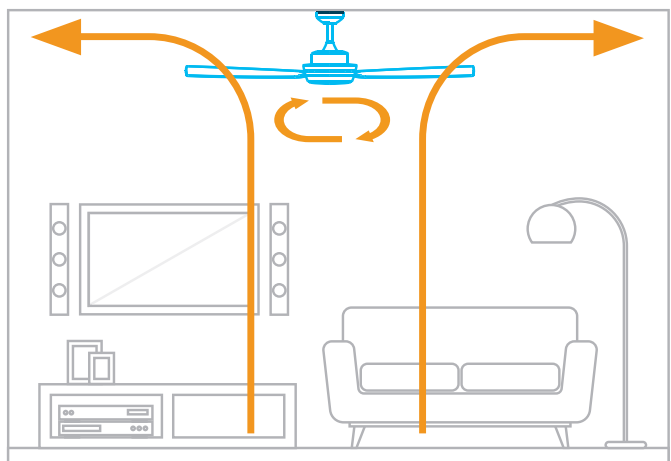

- In winter, the fan should be set to blow upward
- Using a ceiling fan in winter saves energy by allowing a lower thermostat setting
- Forward or reverse rotation can be selected according to the season

Specifications

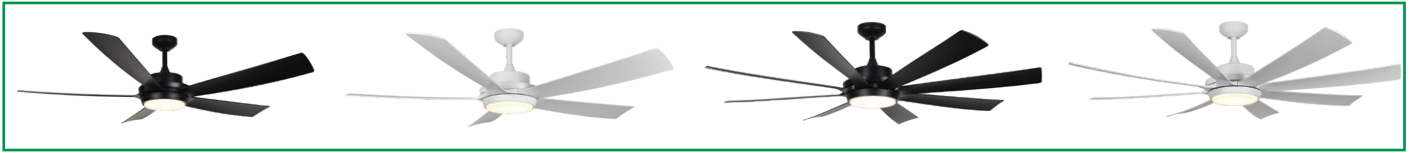

Ceiling Fans	60 inches 8-blade with LED light		60 inches 5-blade with LED light	
Model Name	VCA608LED-HEWH	VCA608LED-HEBK	VCA605LED-HEWH	VCA605LED-HEBK
Finish	Matt White	Matt Black	Matt White	Matt Black
Blade Span	60"		60"	
Number of Blade	8		5	
Airflow (CFM)	6100		6400	
Power Consumption (W)	17		20	
Efficiency (CFM/W)	383		334	
Control Type	Remote Control		Remote Control	
Fan Speed	6		6	
Reverse Capable	Yes		Yes	
Light Type	20W Integrated LED (1500 lm)		20W Integrated LED (1500 lm)	
Dimmable	Yes		Yes	
Indoor/Outdoor Usage	Indoor / Outdoor		Indoor / Outdoor	

Ceiling Fans	72 inches 8-blade with LED light		72 inches 5-blade with LED light	
Model Name	VCA728LED-HEWH	VCA728LED-HEBK	VCA725LED-HEWH	VCA725LED-HEBK
Finish	Matt White	Matt Black	Matt White	Matt Black
Blade Span	72"		72"	
Number of Blade	8		5	
Airflow (CFM)	7200		7900	
Power Consumption (W)	25		25	
Efficiency (CFM/W)	409		339	
Control Type	Remote Control		Remote Control	
Fan Speed	6		6	
Reverse Capable	Yes		Yes	
Light Type	20W Integrated LED (1500 lm)		20W Integrated LED (1500 lm)	
Dimmable	Yes		Yes	
Indoor/Outdoor Usage	Indoor / Outdoor		Indoor / Outdoor	



remote control included



Dealer Address:



Learn more about Delta Breez Ventilation Fans, the best indoor air quality solution for green construction.

www.deltabreez.com

Delta Electronics (Americas) Ltd.
46101 Fremont Blvd.
Fremont, CA 94538

Technical support: (888) 979-9889
BreezTechSupport@deltaww.com

Customer sales support: (877) 685-4384
BreezSalesSupport@deltaww.com

Fax: (510) 226-5098